

# SERVICE MANUAL

W840SU-T

*notebook*





**Notebook Computer**

**W840SU-T**

**Service Manual**

### Notice

The company reserves the right to revise this publication or to change its contents without notice. Information contained herein is for reference only and does not constitute a commitment on the part of the manufacturer or any subsequent vendor. They assume no responsibility or liability for any errors or inaccuracies that may appear in this publication nor are they in anyway responsible for any loss or damage resulting from the use (or misuse) of this publication.

This publication and any accompanying software may not, in whole or in part, be reproduced, translated, transmitted or reduced to any machine readable form without prior consent from the vendor, manufacturer or creators of this publication, except for copies kept by the user for backup purposes.

Brand and product names mentioned in this publication may or may not be copyrights and/or registered trademarks of their respective companies. They are mentioned for identification purposes only and are not intended as an endorsement of that product or its manufacturer.

Version 1.0  
September 2013

### Trademarks

**Intel, and Intel Core** are trademarks of Intel Corporation.

**Windows<sup>®</sup>** is a registered trademark of Microsoft Corporation.

Other brand and product names are trademarks and /or registered trademarks of their respective companies.

## About this Manual

This manual is intended for service personnel who have completed sufficient training to undertake the maintenance and inspection of personal computers.

It is organized to allow you to look up basic information for servicing and/or upgrading components of the *W840SU-T* series notebook PC.

The following information is included:

Chapter 1, Introduction, provides general information about the location of system elements and their specifications.

Chapter 2, Disassembly, provides step-by-step instructions for disassembling parts and subsystems and how to upgrade elements of the system.

Appendix A, Part Lists

Appendix B, Schematic Diagrams

Appendix C, Updating the FLASH ROM BIOS

## IMPORTANT SAFETY INSTRUCTIONS

Follow basic safety precautions, including those listed below, to reduce the risk of fire, electric shock and injury to persons when using any electrical equipment:

1. Do not use this product near water, for example near a bath tub, wash bowl, kitchen sink or laundry tub, in a wet basement or near a swimming pool.
2. Avoid using a telephone (other than a cordless type) during an electrical storm. There may be a remote risk of electrical shock from lightning.
3. Do not use the telephone to report a gas leak in the vicinity of the leak.
4. Use only the power cord and batteries indicated in this manual. Do not dispose of batteries in a fire. They may explode. Check with local codes for possible special disposal instructions.
5. This product is intended to be supplied by a Listed Power Unit as follows:
  - AC Input of 100 - 240V, 50 - 60Hz, DC Output of 19V, 3.42A (65 Watts) minimum AC/DC Adapter.

## CAUTION

**This Computer's Optical Device is a Laser Class 1 Product**

## FCC Statement

This device complies with Part 15 of the FCC Rules. Operation is subject to the following two conditions:

This device may not cause harmful interference.

This device must accept any interference received, including interference that may cause undesired operation.

## Instructions for Care and Operation

The notebook computer is quite rugged, but it can be damaged. To prevent this, follow these suggestions:

1. **Don't drop it, or expose it to shock.** If the computer falls, the case and the components could be damaged.



2. **Keep it dry, and don't overheat it.** Keep the computer and power supply away from any kind of heating element. This is an electrical appliance. If water or any other liquid gets into it, the computer could be badly damaged.

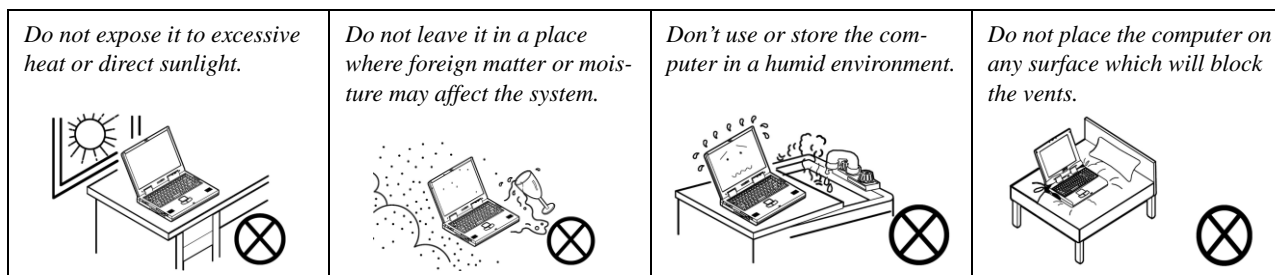

3. **Follow the proper working procedures for the computer.** Shut the computer down properly and don't forget to save your work. Remember to periodically save your data as data may be lost if the battery is depleted.

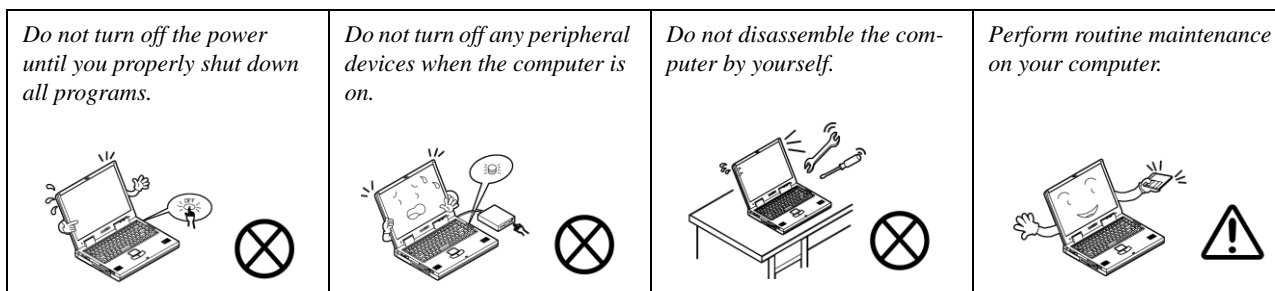

4. **Avoid interference.** Keep the computer away from high capacity transformers, electric motors, and other strong magnetic fields. These can hinder proper performance and damage your data.
5. **Take care when using peripheral devices.**

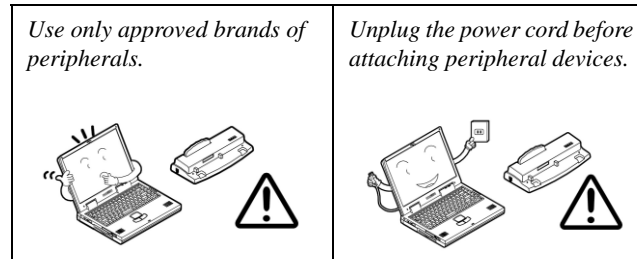

## Power Safety

The computer has specific power requirements:

- Only use a power adapter approved for use with this computer.
- Your AC adapter may be designed for international travel but it still requires a steady, uninterrupted power supply. If you are unsure of your local power specifications, consult your service representative or local power company.
- The power adapter may have either a 2-prong or a 3-prong grounded plug. The third prong is an important safety feature; do not defeat its purpose. If you do not have access to a compatible outlet, have a qualified electrician install one.
- When you want to unplug the power cord, be sure to disconnect it by the plug head, not by its wire.
- Make sure the socket and any extension cord(s) you use can support the total current load of all the connected devices.
- Before cleaning the computer, make sure it is disconnected from any external power supplies.

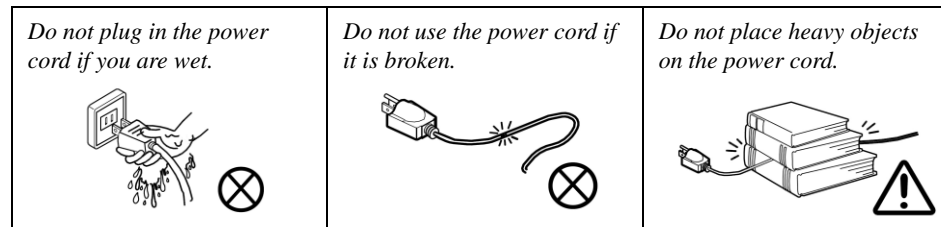

### Power Safety Warning

Before you undertake any upgrade procedures, make sure that you have turned off the power, and disconnected all peripherals and cables (including telephone lines and power cord). It is advisable to also remove your battery in order to prevent accidentally turning the machine on.



## Battery Precautions

- Only use batteries designed for this computer. The wrong battery type may explode, leak or damage the computer.
- Do not continue to use a battery that has been dropped, or that appears damaged (e.g. bent or twisted) in any way. Even if the computer continues to work with a damaged battery in place, it may cause circuit damage, which may possibly result in fire.
- Recharge the batteries using the notebook's system. Incorrect recharging may make the battery explode.
- Do not try to repair a battery pack. Refer any battery pack repair or replacement to your service representative or qualified service personnel.
- Keep children away from, and promptly dispose of a damaged battery. Always dispose of batteries carefully. Batteries may explode or leak if exposed to fire, or improperly handled or discarded.
- Keep the battery away from metal appliances.
- Affix tape to the battery contacts before disposing of the battery.
- Do not touch the battery contacts with your hands or metal objects.

## Battery Guidelines

The following can also apply to any backup batteries you may have.

- If you do not use the battery for an extended period, then remove the battery from the computer for storage.
- Before removing the battery for storage charge it to 60% - 70%.
- Check stored batteries at least every 3 months and charge them to 60% - 70%.



### Battery Disposal

The product that you have purchased contains a rechargeable battery. The battery is recyclable. At the end of its useful life, under various state and local laws, it may be illegal to dispose of this battery into the municipal waste stream. Check with your local solid waste officials for details in your area for recycling options or proper disposal.

### Caution

Danger of explosion if battery is incorrectly replaced. Replace only with the same or equivalent type recommended by the manufacturer. Discard used battery according to the manufacturer's instructions.

### Battery Level

Click the battery icon  in the taskbar to see the current battery level and charge status. A battery that drops below a level of 10% will not allow the computer to boot up. Make sure that any battery that drops below 10% is recharged within one week.

### Related Documents

You may also need to consult the following manual for additional information:

#### User's Manual on CD/DVD

This describes the notebook PC's features and the procedures for operating the computer and its ROM-based setup program. It also describes the installation and operation of the utility programs provided with the notebook PC.

### System Startup

1. Remove all packing materials.
2. Place the computer on a stable surface.
3. Insert the battery and make sure it is locked in position.
4. Securely attach any peripherals you want to use with the computer (e.g. keyboard and mouse) to their ports.
5. Attach the AC/DC adapter to the DC-In jack on the right of the computer, then plug the AC power cord into an outlet, and connect the AC power cord to the AC/DC adapter.
6. Use one hand to raise the lid/LCD to a comfortable viewing angle (do not exceed 127 degrees); use the other hand (as illustrated in Figure 1) to support the base of the computer (**Note: Never** lift the computer by the lid/LCD).
7. Press the power button to turn the computer "on".

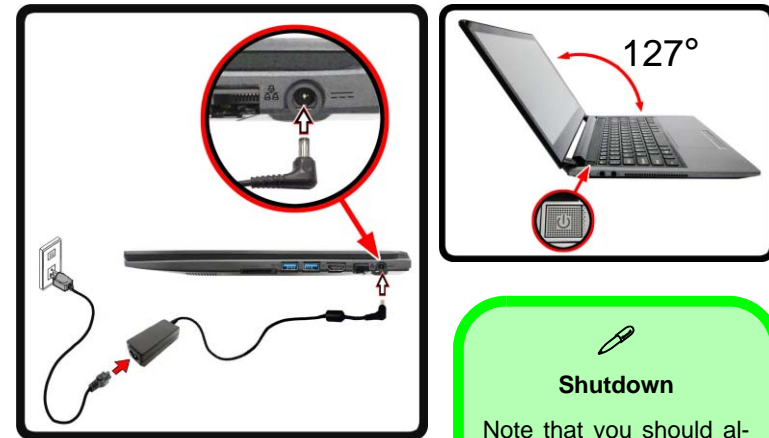

*Figure 1*  
**Opening the Lid/LCD/  
Computer with AC/DC  
Adapter Plugged-In**



#### **Shutdown**

Note that you should always shut your computer down by choosing the **Shut Down** command from the **Power** item in **Settings** in the **Charms Bar** (use the **Windows Logo Key + C** key combination to access the **Charms Bar**) in **Windows 8**. This will help prevent hard disk or system problems.

## Contents

<b>Introduction .....</b>	<b>1-1</b>	<b>Schematic Diagrams.....</b>	<b>B-1</b>
Overview .....	1-1	System Block Diagram .....	B-2
Specifications .....	1-2	Processor 1/11 .....	B-3
External Locator - Top View with LCD Panel Open .....	1-4	Processor 2/11 .....	B-4
External Locator - Front & Right Side Views .....	1-5	Processor 3/11 .....	B-5
External Locator - Left Side & Rear View .....	1-6	Processor 4/11 .....	B-6
External Locator - Bottom View .....	1-7	Processor 5/11 .....	B-7
Mainboard Overview - Top (Key Parts) .....	1-8	Processor 6/11 .....	B-8
Mainboard Overview - Bottom (Key Parts) .....	1-9	Processor 7/11 .....	B-9
Mainboard Overview - Top (Connectors) .....	1-10	Processor 8/11 .....	B-10
Mainboard Overview - Bottom (Connectors) .....	1-11	Processor 9/11 .....	B-11
<b>Disassembly .....</b>	<b>2-1</b>	Processor 10/11 .....	B-12
Overview .....	2-1	Processor 11/11 .....	B-13
Maintenance Tools .....	2-2	DDR3 SO-DIMM_0 .....	B-14
Connections .....	2-2	DDR3 SO-DIMM_1 .....	B-15
Maintenance Precautions .....	2-3	PANEL, INVERTER .....	B-16
Disassembly Steps .....	2-4	VGA PCI-E Interface .....	B-17
Removing the Battery .....	2-5	VGA Frame Buffer Interface .....	B-18
Removing the System Memory (RAM) .....	2-6	VGA Frame Buffer A .....	B-19
Removing the Hard Disk Drive .....	2-8	VGA Frame Buffer B .....	B-20
Removing the SSD Module .....	2-10	VGA I/O .....	B-21
Removing the Wireless LAN Module .....	2-11	VGA NVVDD Decoupling .....	B-22
Removing the Keyboard .....	2-12	PS8625 .....	B-23
<b>Part Lists .....</b>	<b>A-1</b>	Card Reader / LAN RTL8411B .....	B-24
Part List Illustration Location .....	A-2	WLAN, MSATA .....	B-25
Top .....	A-3	HDMI, RJ45, Fan .....	B-26
Bottom .....	A-4	Audio Codec ALC282 .....	B-27
HDD .....	A-5	USB Charger, USB, LED .....	B-28
LCD .....	A-6	KBC-ITE IT8587 .....	B-29
		CCD, TPM, I/O Connector, LID .....	B-30

## Preface

---

KBC-ITE IT8587E .....	B-31
Charger, DC In .....	B-32
1.05V .....	B-33
VDD3, VDD5 .....	B-34
1.8VS, 1.5VS, 5V, 5VS, SATA_5VS .....	B-35
DDR 1.5V or 1.35V / 0.75VS PCH 1.5VS .....	B-36
VCORE .....	B-37
N14P, NVVDD, PEX, FBVDDQ .....	B-38
Audio Board .....	B-39
HDD Board .....	B-40
Click Board .....	B-41
LED Board .....	B-42
Power Sequence .....	B-43

## **Updating the FLASH ROM BIOS..... C-1**

Download the BIOS .....	C-1
Unzip the downloaded files to a bootable CD/DVD/ or USB Flash drive .....	C-1
Set the computer to boot from the external drive .....	C-1
Use the flash tools to update the BIOS .....	C-2
Restart the computer (booting from the HDD) .....	C-2

# Chapter 1: Introduction

## Overview

This manual covers the information you need to service or upgrade the **W840SU-T** series notebook computer. Information about operating the computer (e.g. getting started, and the *Setup* utility) is in the *User's Manual*. Information about drivers (e.g. VGA & audio) is also found in the *User's Manual*. The manual is shipped with the computer.

Operating systems (e.g. *Window 8*, etc.) have their own manuals as do application softwares (e.g. word processing and database programs). If you have questions about those programs, you should consult those manuals.

The **W840SU-T** series notebook is designed to be upgradeable. See *Disassembly on page 2 - 1* for a detailed description of the upgrade procedures for each specific component. Please take note of the warning and safety information indicated by the “” symbol.

The balance of this chapter reviews the computer's technical specifications and features.

## Introduction

# Specifications



### Latest Specification Information

The specifications listed here are correct at the time of sending them to the press. Certain items (particularly processor types/speeds) may be changed, delayed or updated due to the manufacturer's release schedule. Check with your service center for more details.



### CPU

The CPU is not a user serviceable part. Accessing the CPU in any way may violate your warranty.

### Processor Options

#### Intel® Core™ i7 Processor

##### i7-4500U (1.80GHz)

4MB L3 Cache, **22nm**, DDR3L-1600MHz, TDP 15W

#### Intel® Core™ i5 Processor

##### i5-4200U (1.60GHz)

3MB L3 Cache, **22nm**, DDR3L-1600MHz, TDP 15W

#### Intel® Core™ i3 Processor

##### i3-4010U (1.70GHz)

3MB L3 Cache, **22nm**, DDR3L-1600MHz, TDP 15W

### BIOS

96Mb SPI Flash ROM

AMI BIOS

### Memory

Two 204 Pin SO-DIMM Sockets Supporting **DDR3L 1600MHz** Memory

Memory Expandable up to 16GB

(The real memory operating frequency depends on the FSB of the processor.)

### LCD

14" (35.56cm) HD/ HD+/ FHD (Thickness: 3.2mm)

### Multi Touch

### Storage

One Changeable 2.5" 7.0mm (h) SATA HDD

(**Factory Option**) One mSATA Solid State Drive (SSD)

### Audio

High Definition Audio Compliant Interface

2 \* Built-In Speakers

Built-In Microphone

### Security

Security (Kensington® Type) Lock Slot

BIOS Password

(**Factory Option**) TPM 1.2

### Keyboard

"WinKey" keyboard

### Pointing Device

Built-in Touchpad

### Interface

Two USB 3.0 Ports

One HDMI-Out Port

One Headphone-Out Jack

One Microphone-In Jack

One RJ-45 LAN Jack

One DC-in Jack

### Mini Card Slot

Slot 1 for **WLAN** Module or **WLAN and Bluetooth** Combo Module

(**Factory Option**) Slot 2 for **3G** Module or mSATA **SSD**

### Video Adapter

#### Intel HD Graphics 4400

Dynamic Frequency (Intel Dynamic Video Memory Technology for up to **1.7GB**)

Microsoft DirectX® 11 Compatible

### Card Reader

Embedded Multi-in-1 Push-Push Card Reader

MMC (MultiMedia Card) / RS MMC

SD (Secure Digital) / Mini SD / SDHC/ SDXC

## Communication

Built-In 10/100/1000Mb Ethernet LAN  
1M HD PC Camera Module  
(Factory Option) 3G Mini-Card Module

### WLAN/ Bluetooth Half Mini-Card Modules:

(Factory Option) Intel® Wireless-AC 7260 Wireless LAN  
(802.11a/c) + Bluetooth 4.0

(Factory Option) Intel® Wireless-N 7260 Wireless LAN  
(802.11a/g/n) + Bluetooth 4.0

(Factory Option) Intel® Wireless-N 7260 Wireless LAN  
(802.11b/g/n)+ Bluetooth 4.0

(Factory Option) Intel® Wireless-N 7260 Wireless LAN  
(802.11a/g/n)

## Environmental Spec

### Temperature

Operating: 5°C - 35°C  
Non-Operating: -20°C - 60°C

### Relative Humidity

Operating: 20% - 80%  
Non-Operating: 10% - 90%

## Power

Full Range AC/DC Adapter  
AC Input: 100 - 240V, 50 - 60Hz  
DC Output: 19V, 3.42A (**65W**)  
4 Cell Smart Lithium-Ion Battery Pack, 44.6WH

## Dimensions & Weight

340mm (w) \* 240mm (d) \* 22.8mm (h)  
**2.0kg** (with Battery)

## Introduction

*Figure 1*  
**Top View**

1. PC Camera
2. PC Camera LED
3. Built-In Microphone
4. LCD
5. Power Button
6. Keyboard
7. Touchpad & Buttons

## External Locator - Top View with LCD Panel Open





## External Locator - Front & Right Side Views

FRONT VIEW



*Figure 2*  
**Front View**  
1. LED Indicator

RIGHT SIDE VIEW



*Figure 3*  
**Right Side View**  
1. Multi-in-1 Card Reader  
2. USB 3.0 Ports  
3. HDMI-Out Port  
4. RJ-45 LAN Jack  
5. DC-In Jack

**Introduction**

**External Locator - Left Side & Rear View**

*Figure 4*  
**Left Side View**

- 1. Security Lock Slot
- 2. Microphone-In Jack
- 3. Headphone-Out Jack
- 4. Vent/Fan Intake/Outlet

LEFT SIDE VIEW



*Figure 5*  
**Rear View**

- 1. Battery

REAR VIEW



## External Locator - Bottom View

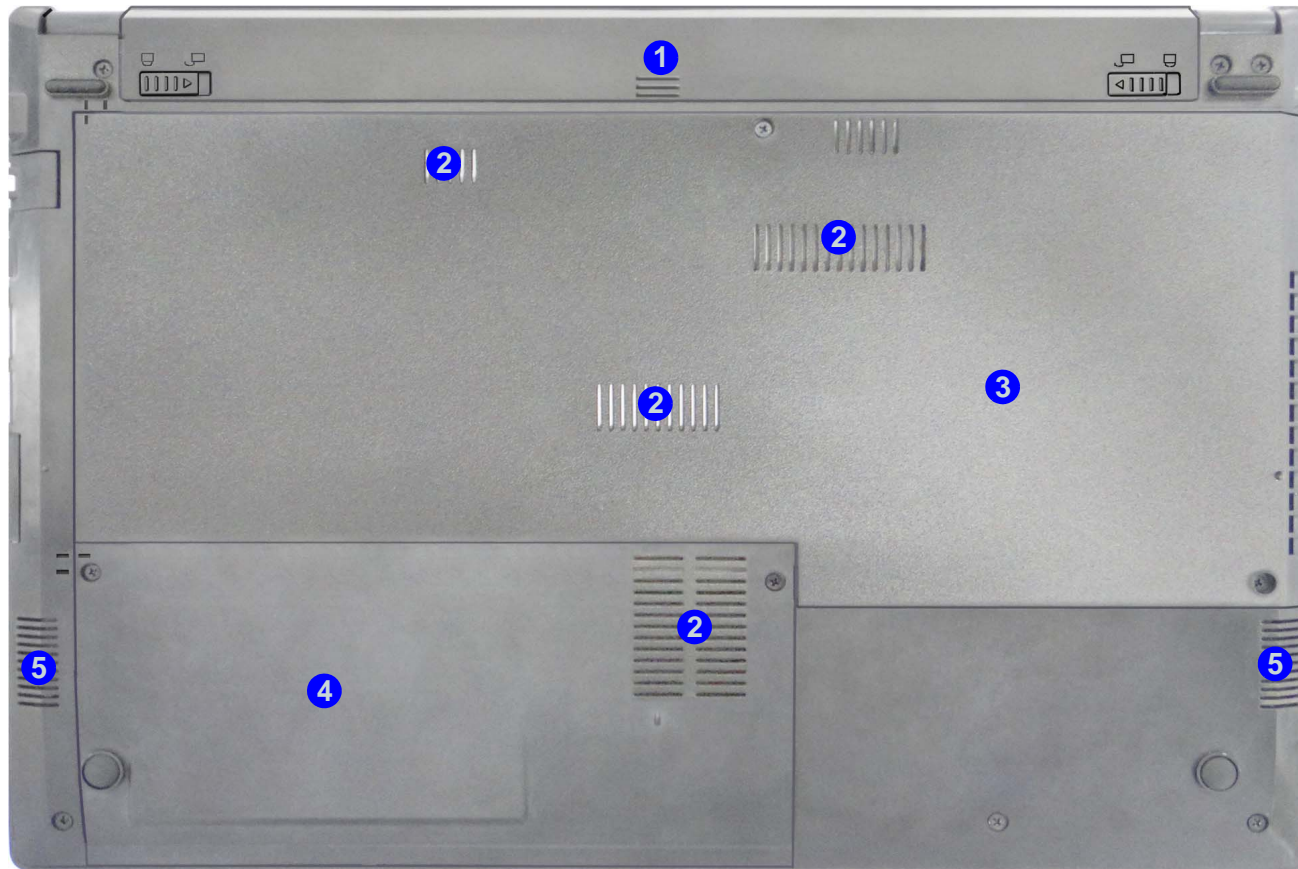

*Figure 6*  
**Bottom View**

1. Battery
2. Vent/Fan Intake/Outlet
3. Component Bay Cover
4. HDD Bay
5. Speakers



### Overheating

To prevent your computer from overheating, make sure nothing blocks any vent while the computer is in use.

## Introduction

---

*Figure 7*  
**Mainboard Top  
Key Parts**

# Mainboard Overview - Top (Key Parts)

1. KBC-ITE IT8518
- 2.

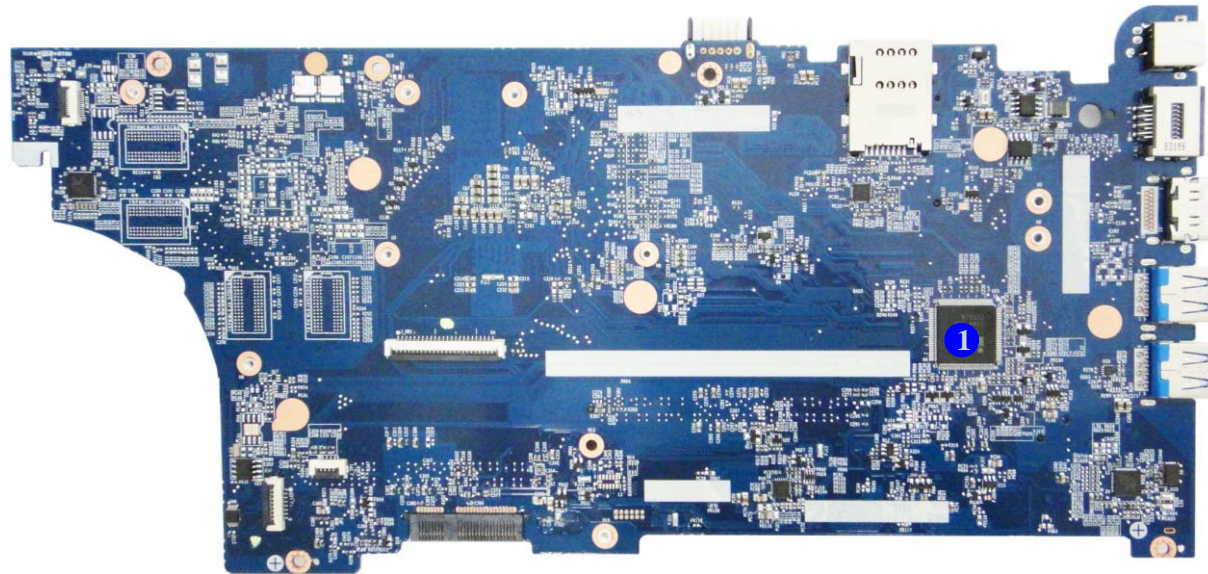

## Mainboard Overview - Bottom (Key Parts)

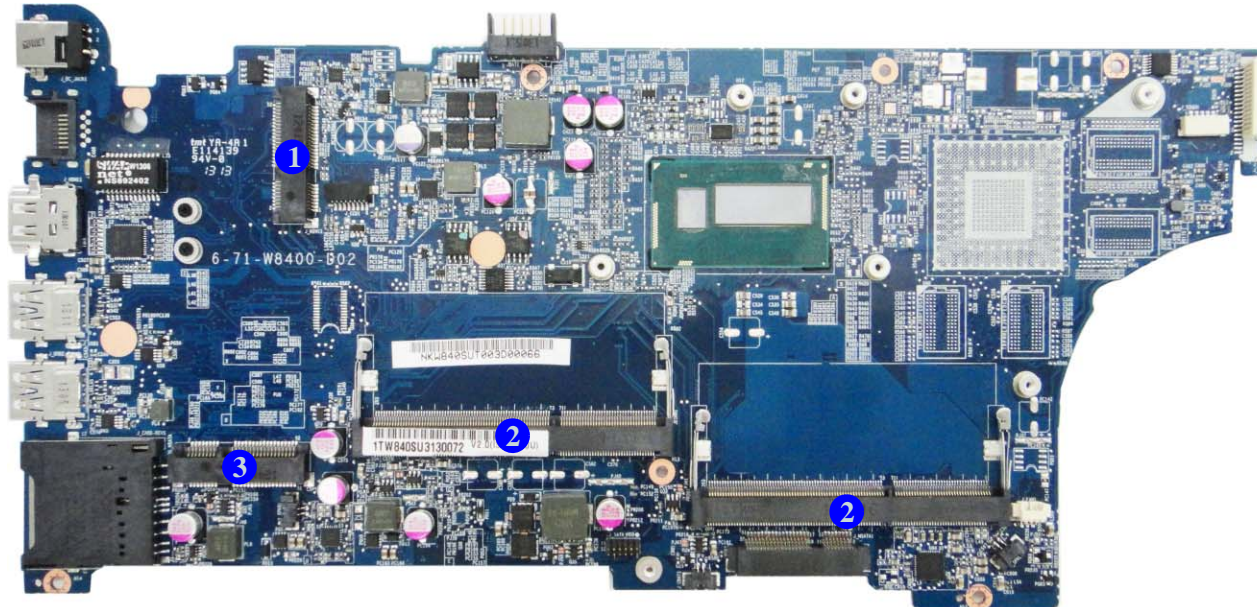

*Figure 8*  
**Mainboard Bottom  
Key Parts**

1. Mini-Card Connector (3G Module)
2. Memory Slots (DDR3 SO-DIMM)
3. Mini-Card Connector (WLAN Module)

## Introduction

*Figure 9*  
**Mainboard Top  
Connectors**

## Mainboard Overview - Top (Connectors)

- 1.
2. Speaker Cable Connector
3. Audio Board Cable Connector
4. Keyboard Cable Connector
5. USB Port 3.0
6. HDMI-Out Port
7. RJ-45 LAN Jack
8. DC-In Jack

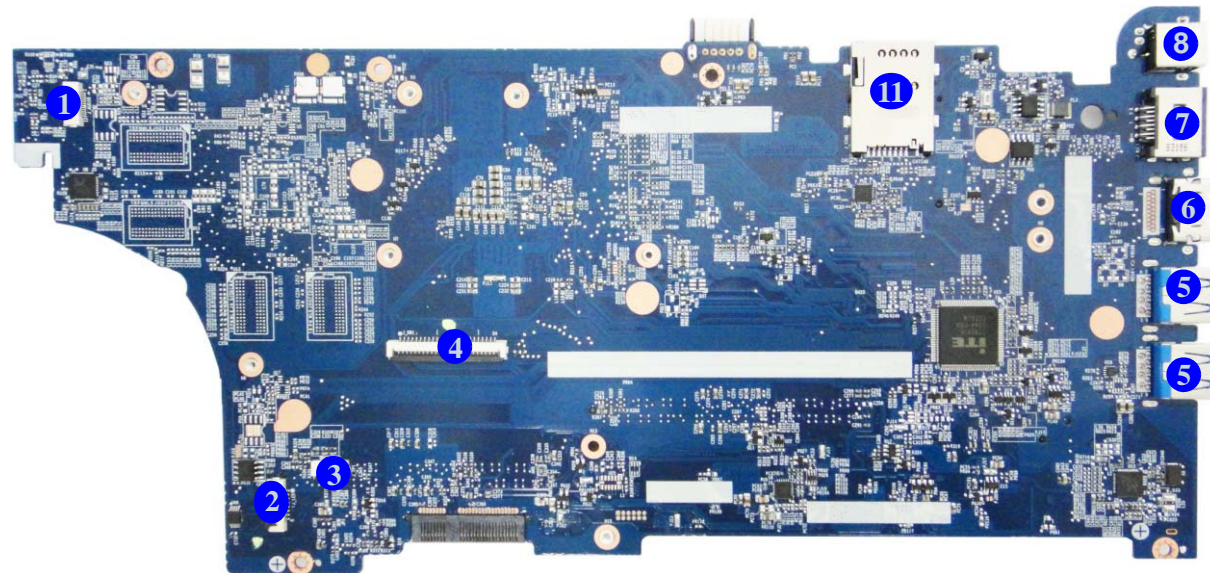

## Mainboard Overview - Bottom (Connectors)

*Figure 10*  
**Mainboard Bottom  
Connectors**

1. Multi-in-1 Card Reader
2. Battery Connector
3. ODD Connector
- 4.
5. \

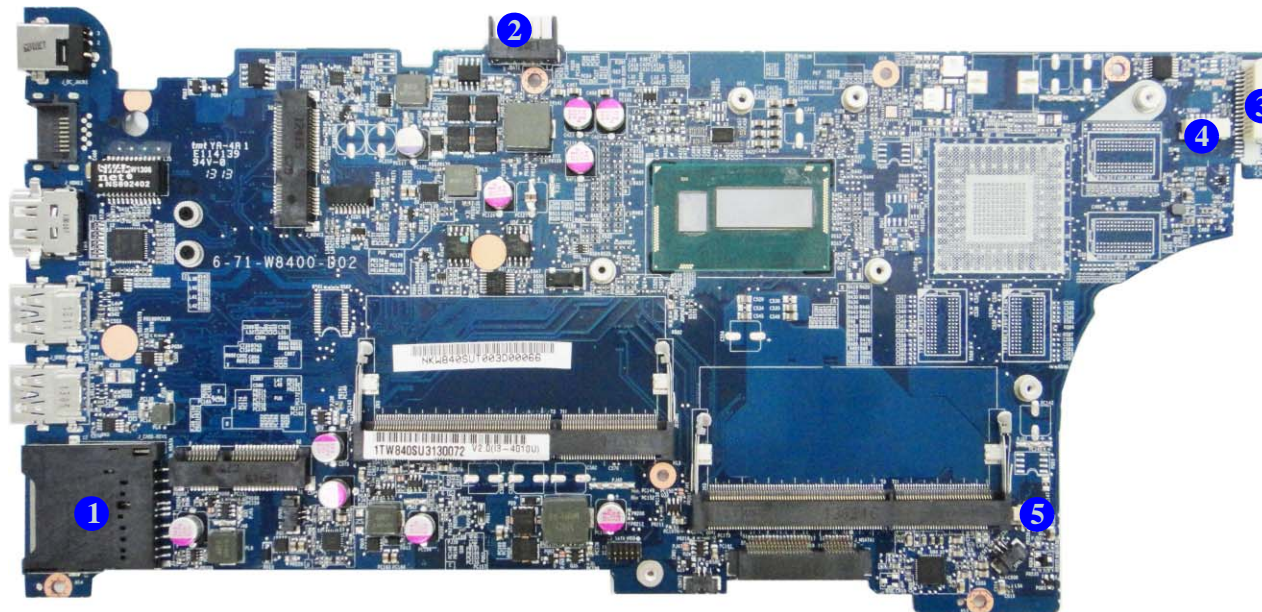





# Chapter 2: Disassembly

## Overview

This chapter provides step-by-step instructions for disassembling the *W840SU-T* series notebook's parts and subsystems. When it comes to reassembly, reverse the procedures (unless otherwise indicated).

We suggest you completely review any procedure before you take the computer apart.

Procedures such as upgrading/replacing the RAM, optical device and hard disk are included in the User's Manual but are repeated here for your convenience.

To make the disassembly process easier each section may have a box in the page margin. Information contained under the figure # will give a synopsis of the sequence of procedures involved in the disassembly procedure. A box with a  lists the relevant parts you will have after the disassembly process is complete. **Note:** The parts listed will be for the disassembly procedure listed ONLY, and not any previous disassembly step(s) required. Refer to the part list for the previous disassembly procedure. The amount of screws you should be left with will be listed here also.

A box with a  will also provide any possible helpful information. A box with a  contains warnings.

An example of these types of boxes are shown in the sidebar.

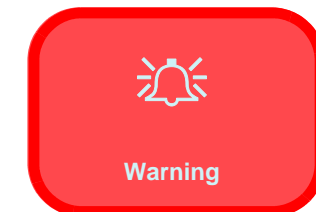
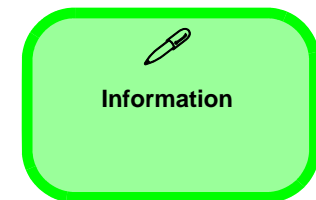

## Disassembly

---

**NOTE:** All disassembly procedures assume that the system is turned **OFF**, and disconnected from any power supply (the battery is removed too).

### Maintenance Tools

The following tools are recommended when working on the notebook PC:

- M3 Philips-head screwdriver
- M2.5 Philips-head screwdriver (magnetized)
- M2 Philips-head screwdriver
- Small flat-head screwdriver
- Pair of needle-nose pliers
- Anti-static wrist-strap

### Connections

Connections within the computer are one of four types:

Locking collar sockets for ribbon connectors	To release these connectors, use a small flat-head screwdriver to gently pry the locking collar away from its base. When replacing the connection, make sure the connector is oriented in the same way. The pin1 side is usually not indicated.
Pressure sockets for multi-wire connectors	To release this connector type, grasp it at its head and gently rock it from side to side as you pull it out. Do not pull on the wires themselves. When replacing the connection, do not try to force it. The socket only fits one way.
Pressure sockets for ribbon connectors	To release these connectors, use a small pair of needle-nose pliers to gently lift the connector away from its socket. When replacing the connection, make sure the connector is oriented in the same way. The pin1 side is usually not indicated.
Board-to-board or multi-pin sockets	To separate the boards, gently rock them from side to side as you pull them apart. If the connection is very tight, use a small flat-head screwdriver - use just enough force to start.

## Maintenance Precautions

The following precautions are a reminder. To avoid personal injury or damage to the computer while performing a removal and/or replacement job, take the following precautions:

1. **Don't drop it.** Perform your repairs and/or upgrades on a stable surface. If the computer falls, the case and other components could be damaged.
2. **Don't overheat it.** Note the proximity of any heating elements. Keep the computer out of direct sunlight.
3. **Avoid interference.** Note the proximity of any high capacity transformers, electric motors, and other strong magnetic fields. These can hinder proper performance and damage components and/or data. You should also monitor the position of magnetized tools (i.e. screwdrivers).
4. **Keep it dry.** This is an electrical appliance. If water or any other liquid gets into it, the computer could be badly damaged.
5. **Be careful with power.** Avoid accidental shocks, discharges or explosions.
  - Before removing or servicing any part from the computer, turn the computer off and detach any power supplies.
  - When you want to unplug the power cord or any cable/wire, be sure to disconnect it by the plug head. Do not pull on the wire.
6. **Peripherals** – Turn off and detach any peripherals.
7. **Beware of static discharge.** ICs, such as the CPU and main support chips, are vulnerable to static electricity. Before handling any part in the computer, discharge any static electricity inside the computer. When handling a printed circuit board, do not use gloves or other materials which allow static electricity buildup. We suggest that you use an anti-static wrist strap instead.
8. **Beware of corrosion.** As you perform your job, avoid touching any connector leads. Even the cleanest hands produce oils which can attract corrosive elements.
9. **Keep your work environment clean.** Tobacco smoke, dust or other air-born particulate matter is often attracted to charged surfaces, reducing performance.
10. **Keep track of the components.** When removing or replacing any part, be careful not to leave small parts, such as screws, loose inside the computer.

## Cleaning

Do not apply cleaner directly to the computer, use a soft clean cloth.

Do not use volatile (petroleum distillates) or abrasive cleaners on any part of the computer.



### Power Safety Warning

Before you undertake any upgrade procedures, make sure that you have turned off the power, and disconnected all peripherals and cables (including telephone lines and power cord). It is advisable to also remove your battery in order to prevent accidentally turning the machine on.

### Disassembly Steps

The following table lists the disassembly steps, and on which page to find the related information. **PLEASE PERFORM THE DISASSEMBLY STEPS IN THE ORDER INDICATED.**

#### To remove the Battery:

1. Remove the battery *page 2 - 5*

#### To remove the System Memory:

1. Remove the battery *page 2 - 5*
2. Remove the system memory *page 2 - 6*

#### To remove the HDD:

1. Remove the battery *page 2 - 5*
2. Remove the HDD *page 2 - 8*

#### To remove the SSD:

1. Remove the battery *page 2 - 5*
2. Remove the SSD *page 2 - 10*

#### To remove the Wireless LAN Module:

1. Remove the battery *page 2 - 5*
2. Remove the WLAN *page 2 - 11*

#### To remove the Keyboard:

1. Remove the battery *page 2 - 5*
2. Remove the keyboard *page 2 - 12*

## Removing the Battery

1. Turn the computer **off**, and turn it over.
2. Slide the latch **1** in the direction of the arrow (*Figure 1a*).
3. Slide the latch **2** in the direction of the arrow, and hold it in place (*Figure 1a*).
4. Slide the battery **3** in the direction of the arrow **4** (*Figure 1b*).
5. Reinsert the battery as illustrated below **5** (*Figure 1c*).

*Figure 1*  
**Battery Removal**

- a. Slide the latch and hold it in place.
- b. Slide the battery out.
- c. Reinsert the battery.

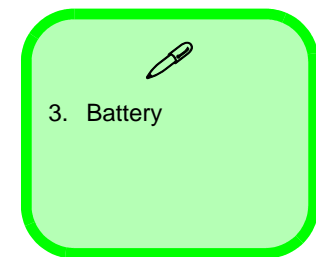
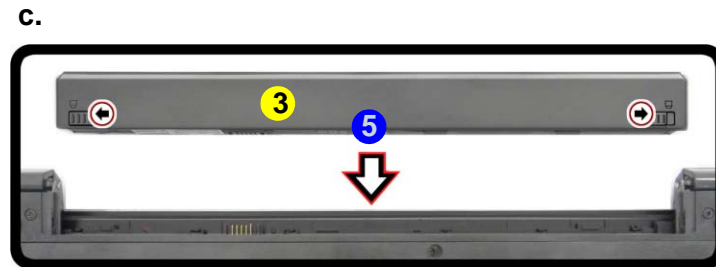
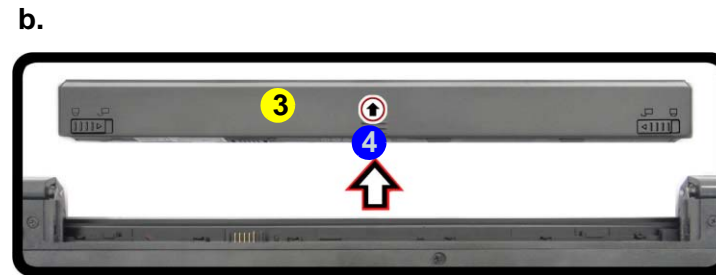
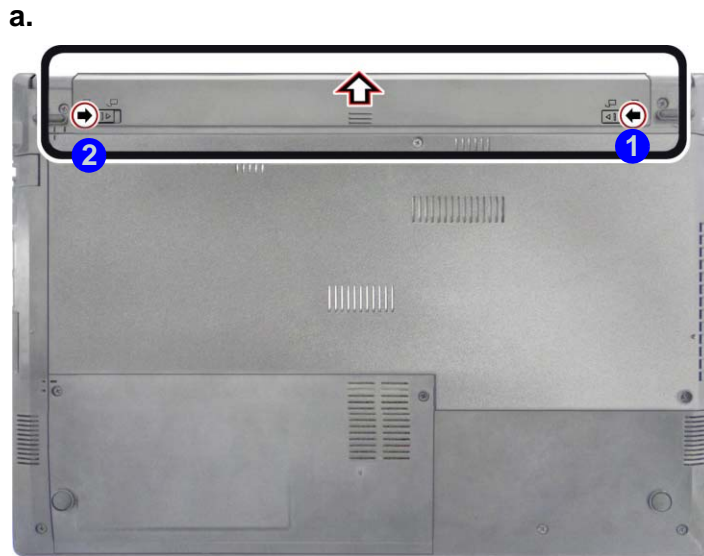

## Disassembly

*Figure 2*  
**RAM Module  
Removal**

- Remove the screws.
- Slide the component bay cover out.
- Remove the component bay cover.

## Removing the System Memory (RAM)

The computer has two memory sockets for 204 pin Small Outline Dual In-line Memory Modules (SO-DIMM) supporting DDR3L Up to 1600 MHz. The SO-DIMM modules supported are 1024MB and 2048MB **DDRIII** Modules. The total memory size is automatically detected by the POST routine once you turn on your computer.

### Memory Upgrade Process

- Turn **off** the computer, turn it over, remove the battery ([page 2 - 5](#)).
- Locate the component bay cover and remove screws **1** - **2** ([Figure 2a](#)).
- Slide the bay cover **3** until the cover and case indicators **4** are aligned ([Figure 2b](#)).
- The RAM modules will be visible at point **5** on the mainboard ([Figure 2b](#)).

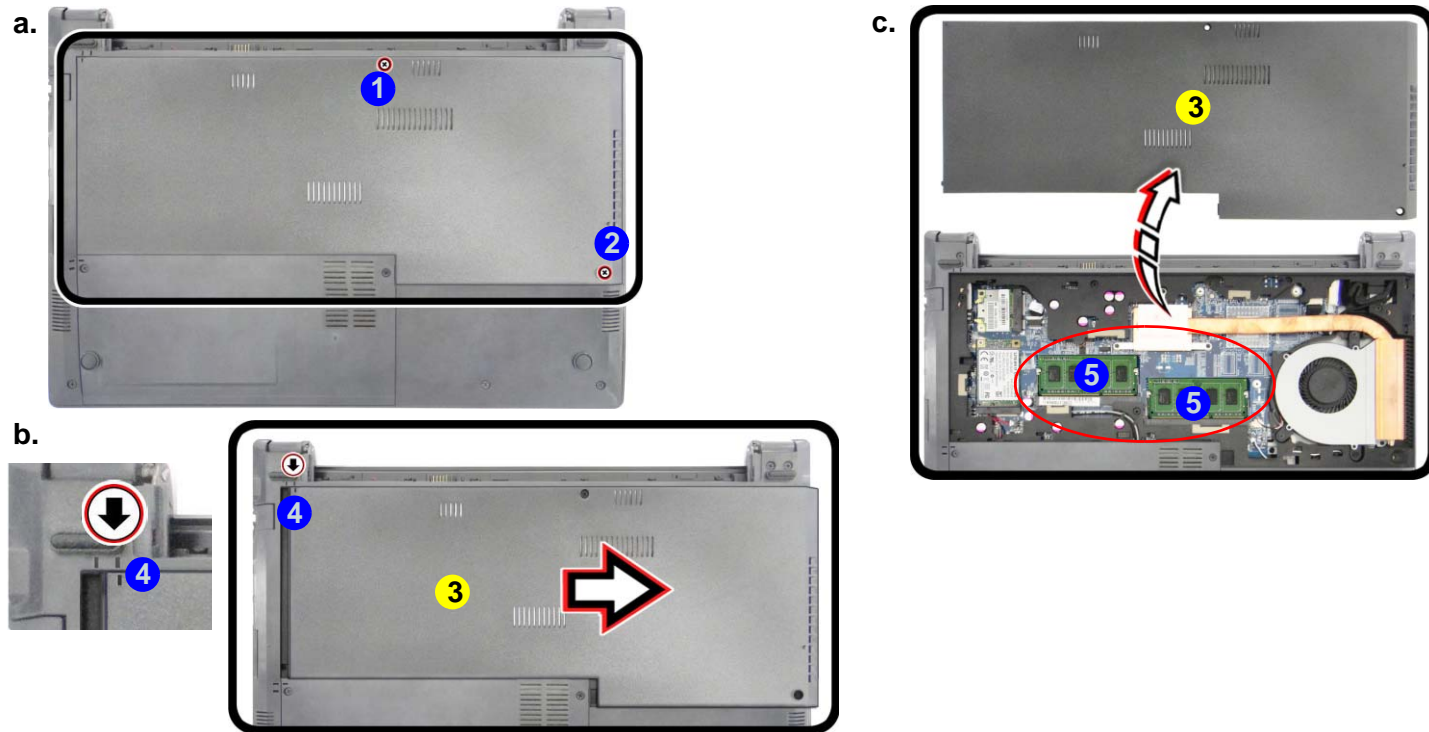

3. Component Bay Cover

- Gently pull the two release latches (6 & 7) on the sides of the memory socket in the direction indicated by the arrows (**Figure 2b**). The RAM module (8) will pop-up, and you can then remove it.
- Pull the latches to release the second module if necessary.
- Insert a new module holding it at about a 30° angle and fit the connectors firmly into the memory slot.
- The module will only fit one way as defined by its pin alignment. Make sure the module is seated as far into the slot as it will go. **DO NOT FORCE IT**; it should fit without much pressure.
- Press the module in and down towards the mainboard until the slot levers click into place to secure the module.
- Reinsert the component bay cover by placing it on the bottom case assembly, and make sure the case markers line up (9).
- Apply downward pressure and sliding the cover in the direction of arrow (10).
- Replace the screws and battery (see [page 2 - 6](#)).
- Restart the computer to allow the BIOS to register the new memory configuration as it starts up.

*Figure 3*  
**RAM Module Removal (contd)**

- Pull the release latches to remove the module(s).
- Remove the module(s).
- Reinstall the component bay cover.

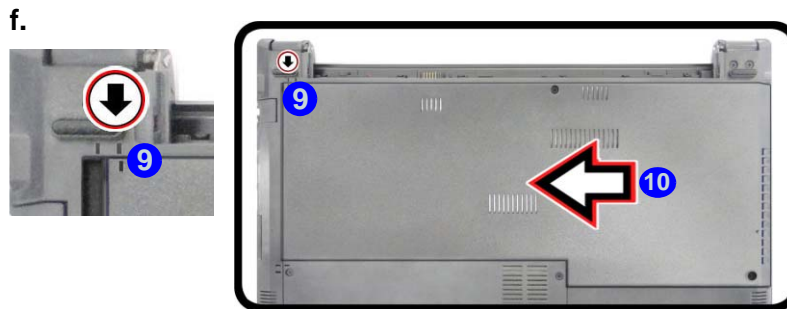
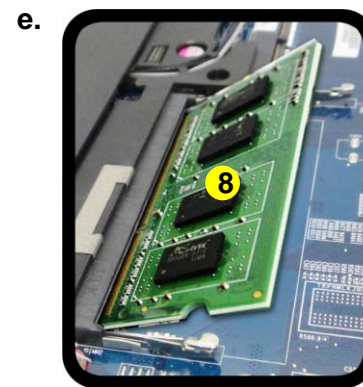
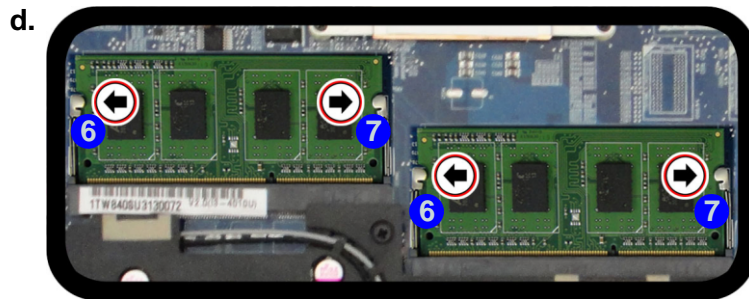

### Contact Warning

Be careful not to touch the metal pins on the module's connecting edge. Even the cleanest hands have oils which can attract particles, and degrade the module's performance.



8. RAM Module

## Removing the Hard Disk Drive

Figure 4  
HDD Assembly  
Removal

The hard disk drive can be taken out to accommodate other 2.5" serial (SATA) hard disk drives with a height of 9.5mm or 7mm (h). Follow your operating system's installation instructions, and install all necessary drivers and utilities (as outlined in **Chapter 4 of the User's Manual**) when setting up a new hard disk.

- a. Remove the screws.
- b. Remove the cover.

### Hard Disk Upgrade Process

1. Turn **off** the computer, turn it over.
2. Locate the hard disk bay cover and remove screws ① - ② from the bottom cover (*Figure 4a*).
3. Slide the bay cover ③ until the cover and case indicators ④ are aligned (*Figure 4b*).

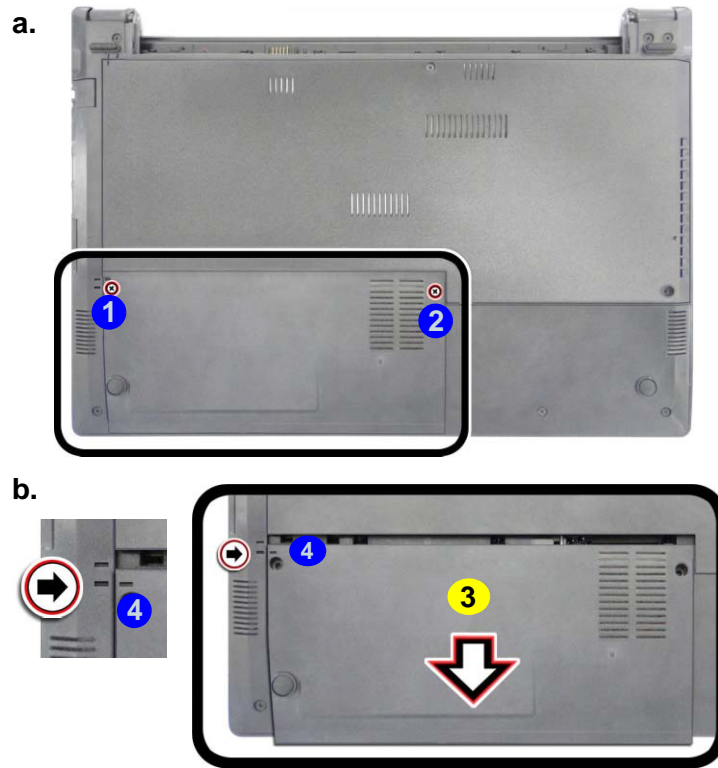



3. Hard Disk Bay Cover

- 2 Screws



**HDD System Warning**

New HDD's are blank. Before you begin make sure:

- You have backed up any data you want to keep from your old HDD.
- You have all the CD-ROMs and FDDs required to install your operating system and programs.
- If you have access to the internet, download the latest application and hardware driver updates for the operating system you plan to install. Copy these to a removable medium.



4. Remove the HDD bay cover **3** (*Figure 5c*).
5. Grip the tab **5** and slide the hard disk assembly in the direction of arrow **6** (*Figure 5d*).
6. Lift the hard disk assembly **7** out of the bay (*Figure 5e*).
7. Remove the screws **8** - **9** and the hard disk cover **10** from the hard disk **11** (*Figure 5f*).
8. Replace the HDD assembly by using a finger to push it in at point **12** in the direction of arrow **13**.
9. Reinsert the HDD bay cover by placing it on the bottom case assembly, and make sure the case markers line up **14**.
10. Apply downward pressure with both thumbs at points **15** & **16** and slide the cover in the direction of the arrows as illustrated.
11. Replace the screws and battery (see [page 2 - 8](#)).

*Figure 5*  
**HDD Assembly Removal (cont'd.)**

- c. Remove the HDD bay cover.
- d. Grip the tab and slide the HDD assembly in the direction of the arrow.
- e. Lift the HDD assembly out of the bay.
- f. Remove the screws and cover from HDD.
- g. Reinstall HDD assembly.
- h. Replace the HDD bay cover.

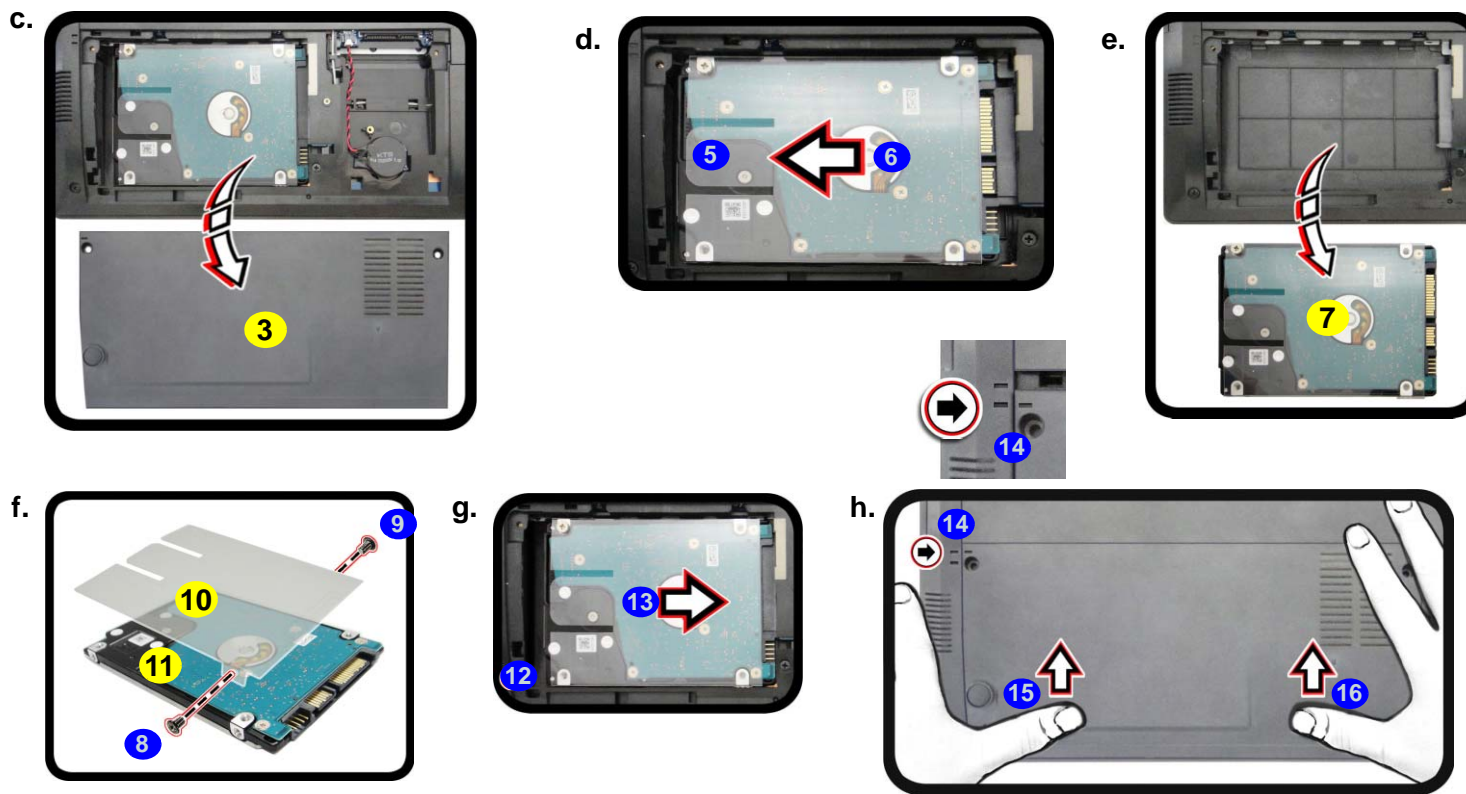

## Disassembly

*Figure 6*  
**SSD Module  
 Removal**

- Locate the SSD.
- Remove the screw.
- The SSD module will pop up.

Note: Make sure you reconnect the antenna cable to the “1 + 2” socket (*Figure 7b*).

## Removing the SSD Module

- Turn **off** the computer, turn it over, remove the battery ([page 2 - 5](#)) and component bay cover ([page 2 - 6](#)).
- The SSD module will be visible at point **1** on the mainboard (*Figure 6a*).
- Remove the screw **2** (*Figure 6b*).
- The SSD module **3** (*Figure 6c*) will pop-up, and you can remove it from the computer.
- Replace the SSD by angling it as illustrated, and then fit the connector firmly into the slot.
- The SSD module's pin alignment will allow it to only fit one way. Make sure the module is seated as far into the slot as it will go. **DO NOT FORCE** the module; it should fit without much pressure.
- Press the SSD module down towards the mainboard and replace screw **2** and the component bay cover.

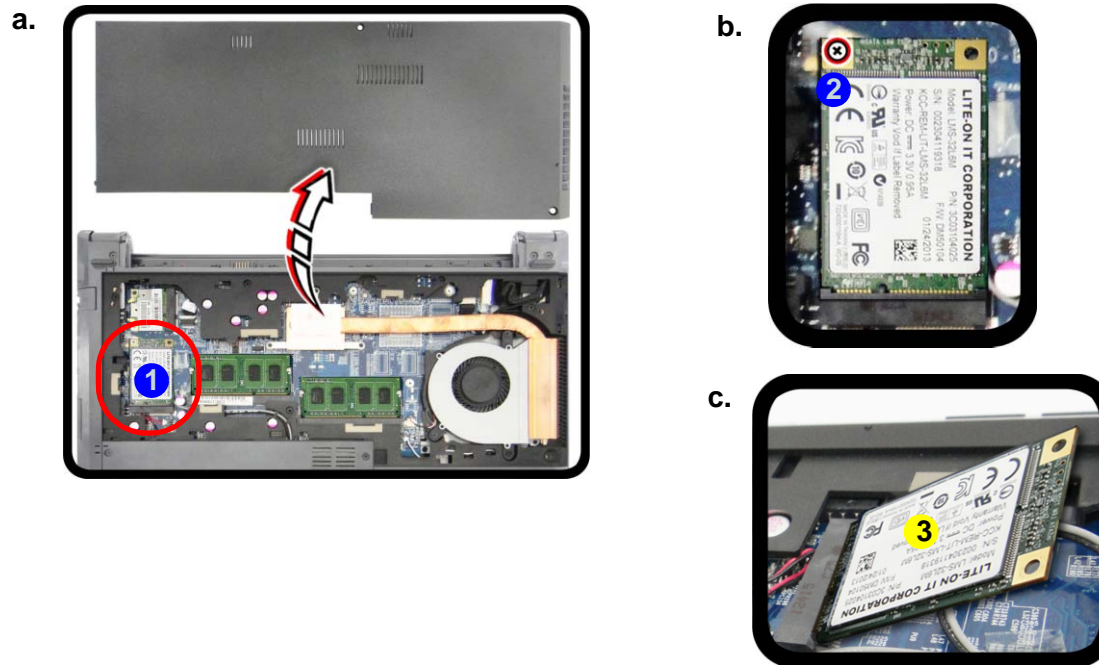

3.SSD Module

- 1 Screw

## Removing the Wireless LAN Module

1. Turn **off** the computer, turn it over, remove the battery ([page 2 - 5](#)) and keyboard ([page 2 - 12](#)).
2. The Wireless LAN module will be visible at point **1** on the mainboard ([Figure 7a](#)).
3. Carefully disconnect the cable **2** & **3**, and then remove the screw **4** ([Figure 7b](#))
4. The Wireless LAN module **5** ([Figure 7c](#)) will pop-up, and you can remove it from the computer.

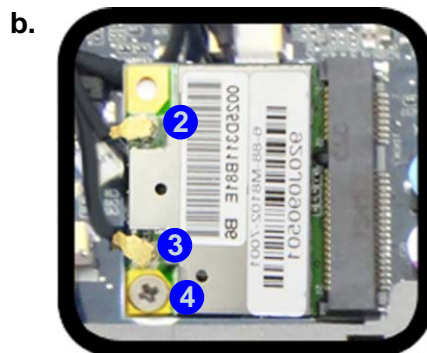
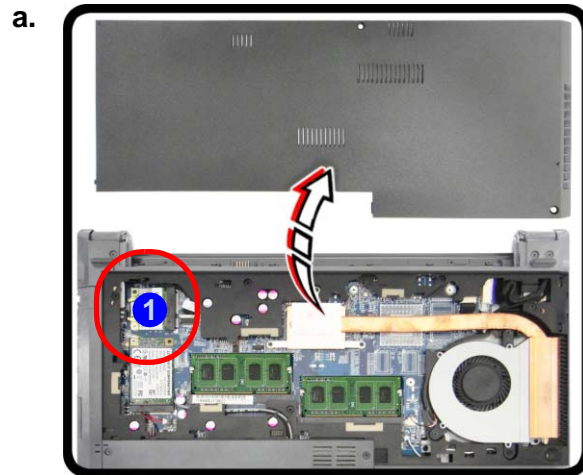

*Figure 7*  
**Wireless LAN  
Module Removal**

- a. Locate the WLAN.
- b. Disconnect the cables and remove the screw.
- c. The WLAN module will pop up.

Note: Make sure you reconnect the antenna cable to the “1 + 2” socket ([Figure 7b](#)).



5. Wireless LAN Module

- 1 Screw

## Disassembly

*Figure 8*  
**Keyboard Removal**

- Lift the center cover.
- Remove the center cover and screws.
- Disconnect the keyboard ribbon cable from the locking collar socket.

## Removing the Keyboard

- Turn **off** the computer, turn it over, remove the battery ([page 2 - 5](#)).
- Lift the center cover at point **1** toward the direction of the arrow **2** ([Figure 8a](#)).
- Remove the center cover module **3** and screws **4** - **7** ([Figure 8b](#)).
- Carefully lift the keyboard **8** up, being careful not to bend the keyboard ribbon cable **9** ([Figure 8c](#)).
- Disconnect the keyboard ribbon cable from the locking collar socket **10** ([Figure 8c](#)).

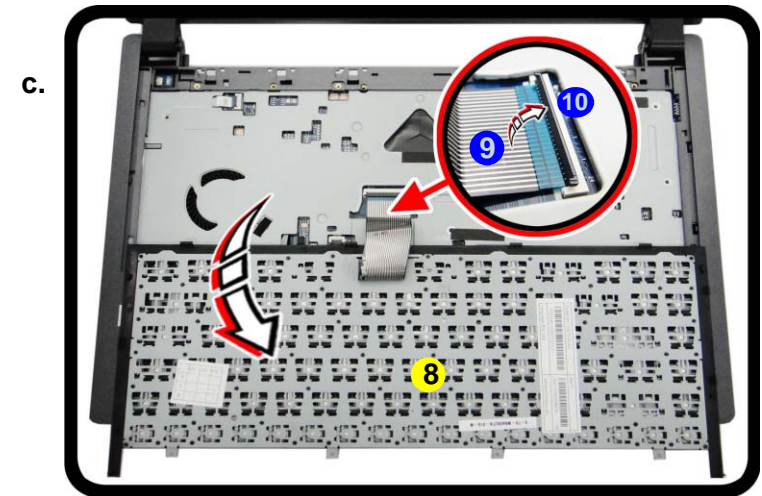
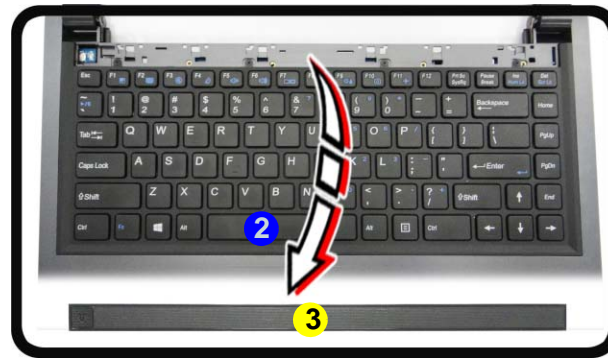

3.Center Cover Module  
8.Keyboard

- 2 Screws

6. Carefully lift up the keyboard **8** off the computer (*Figure 9d*).
7. Reverse the process to install a new keyboard.
8. Replace the center cover module as shown (*Figure 9e*).

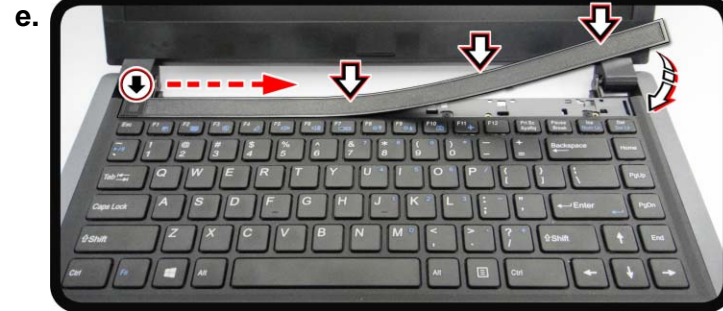

*Figure 9*  
**Keyboard Removal**  
**(cont'd.)**

- d. Remove the keyboard.
- e. Remove the keyboard shielding plate.



---

# Appendix A:Part Lists

This appendix breaks down the *W840SU-T* series notebook's construction into a series of illustrations. The component part numbers are indicated in the tables opposite the drawings.

**Note:** This section indicates the *manufacturer's* part numbers. Your organization may use a different system, so be sure to cross-check any relevant documentation.

**Note:** Some assemblies may have parts in common (especially screws). However, the part lists DO NOT indicate the total number of duplicated parts used.

**Note:** Be sure to check any update notices. The parts shown in these illustrations are appropriate for the system at the time of publication. Over the product life, some parts may be improved or re-configured, resulting in *new* part numbers.

---

## Part List Illustration Location

The following table indicates where to find the appropriate part list illustration.

*Table A - 1*  
**Part List Illustration  
Location**

Part	
Top	<i>page A - 3</i>
Bottom	<i>page A - 4</i>
HDD	<i>page A - 5</i>
LCD	<i>page A - 6</i>



# Top

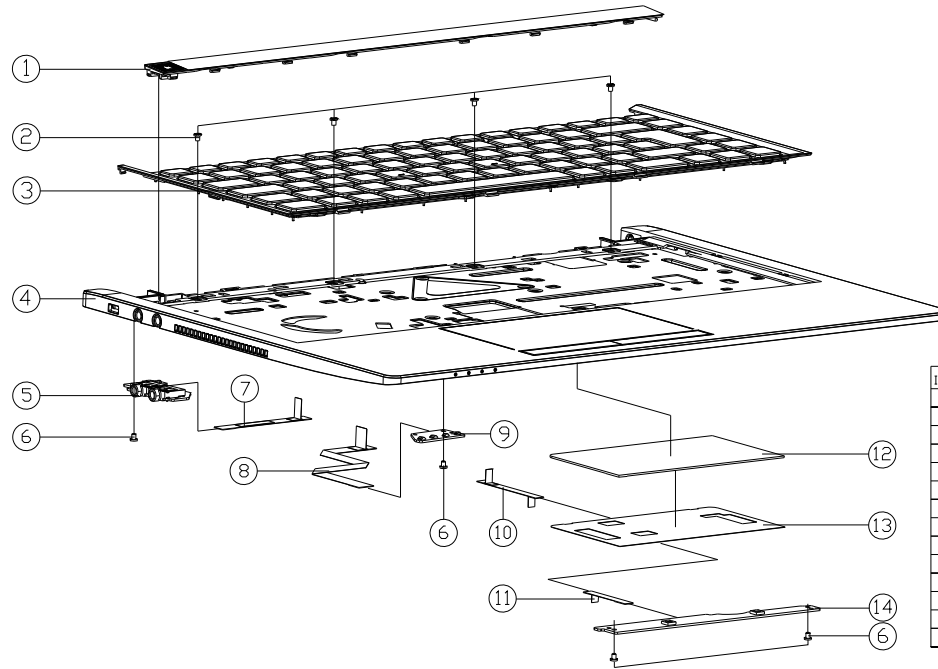

ITEM	PART NAME	PART NO	REMARK
1	CENTER COVER MODULE W840SU-T	6-42-W8402-101	
2	SCREW M2X2.5 K1 BK/Z ICT NY #35 T+0.3	6-35-B6120-2BRD	
3	W/O K/R USA BLACK FRAME (US) MODULE W840SU-T	6-79-W840SU-T-010-W	
4	TOP CASE MODULE W840SU-T	6-39-W8402-011	
5	AUDIO & SWITCH BOARD V3.0 W840SN	6-77-W8402-D03	
6	SCREW M2X3L K1 BK/Z ICT NY #35 T+0.3	6-35-B6120-3RE	
7	FFC CABLE FOR AUDIO TO W8 12PIN W840SU-T(ENLUS)	6-43-W8400-031	
8	FFC CABLE FOR LED TO W8 8PIN W840SU-T(ENLUS)	6-43-W8400-021	
9	LED BOARD V3.0 W840SN	6-77-W8404-D03	
10	FFC CABLE FOR CN1 TO W8 4PIN W840SU-T(ENLUS)	6-43-W8400-011	
11	FFC CABLE FOR CLICK TO TP CN2 4PIN W840SU-T	6-43-W8400-041	
12	TOUCH PAD ELAN SA0550-6200 W650EH	6-49-W65E3-010	
13	MAIN DISPLAY BEZEL BLACK PET/PSA A92 FOR TOUCH W840SU-T	6-40-W8402-021	
14	CLICK BOARD V3.0 W840SN	6-77-W8402-D03	

Figure A - 1  
Top

# Bottom

Figure A - 2  
Bottom

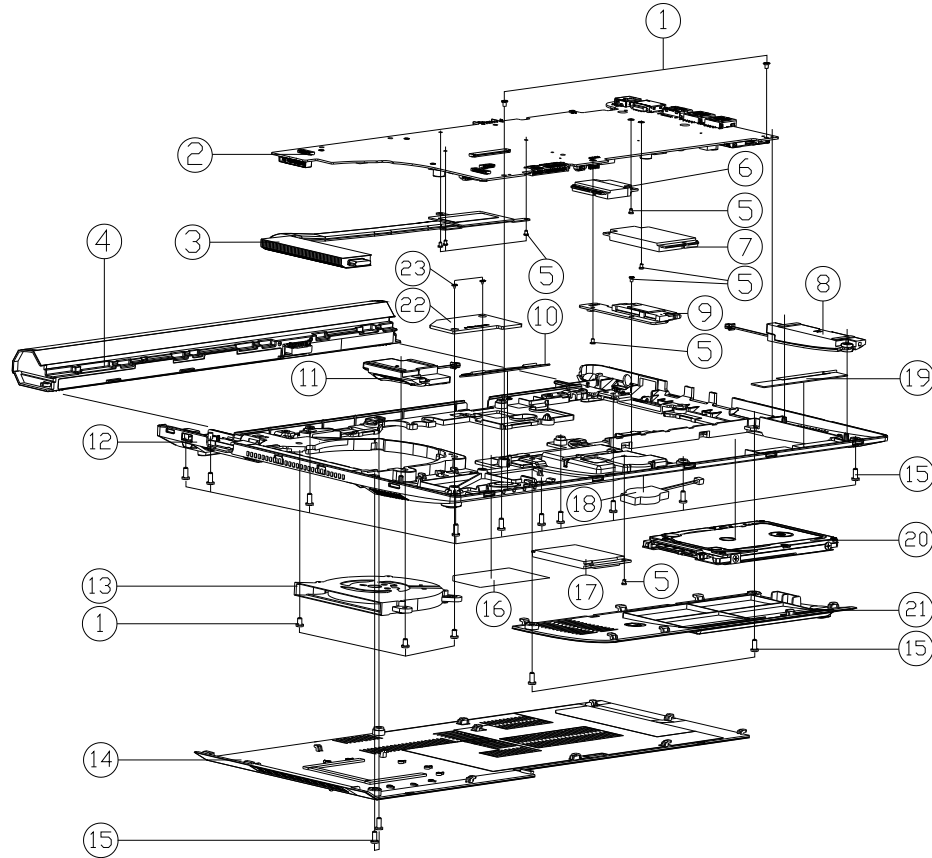

ITEM	PART NAME	PART NO	REMARK
1	SCREW M2.5X5.0L0.4MM KI BK/Z ICT NY	6-35-B6125-5R0	
2	MAIN BOARD V30 (EEP V/3G/W/TPM) W840SU-T	6-77-W840SU0-003	
2	MAIN BOARD V30 (EEP V/D 3G/W/D/TPM) W840SU-T	6-77-W840SU0-003-1	
2	MAIN BOARD V30 (LVS V/D 3G/W/D/TPM) W840SU-T	6-77-W840SU0-003-2	
2	MAIN BOARD V30 (EEP V/D 3G/W/TPM) W840SU-T	6-77-W840SU0-003-3	
3	CPU HEATSINK MODULE W840SU-T	6-31-W8403-102	
4	HEAT SINK COVER FOR CPU HEATSINK MODULE	6-87-W840S-4DL1	
5	SCREW M2X3 KI BK/Z ICT NY (M35 L-83)	6-35-B6120-3RE	
6	FRONT PANEL (OPTION) FOR W840SU-T	6-88-P3702-7000	(OPTION)
6	FRONT PANEL (OPTION) FOR W840SU-T	6-88-P3702-9400	(OPTION)
6	FRONT PANEL (OPTION) FOR W840SU-T	6-88-W345F-7000	(OPTION)
6	FRONT PANEL (OPTION) FOR W840SU-T	6-88-W345F-9400	(OPTION)
6	FRONT PANEL (OPTION) FOR W840SU-T	6-88-W230F-4200	(OPTION)
6	FRONT PANEL (OPTION) FOR W840SU-T	6-88-W230F-4220	(OPTION)
6	FRONT PANEL (OPTION) FOR W840SU-T	6-88-W230F-4200	(OPTION)
6	FRONT PANEL (OPTION) FOR W840SU-T	6-88-W230F-4210	(OPTION)
7	FRONT PANEL (OPTION) FOR W840SU-T	6-88-W650W-8800	(OPTION)
8	SPEAKER R 8OHM 2W 40 PERCENT 4 W840SU-T	6-23-5W840-0R1	
9	SATA HDD BOARD V30 W840SN	6-77-W840J-D03	
10	SATA HDD COVER FOR W840SU-T	6-23-7W840-010	
11	SPEAKER L 8OHM 2W 40 PERCENT 4 W840SU-T	6-23-5W840-0L1	
12	BOTTOM CASE MODULE W840SU-T	6-39-W8403-011	
13	FAN MODULE (FORCECOOL) W840SU-T	6-31-W840S-101	
14	CPU COVER MODULE W840SU-T	6-42-W8408-101	
15	SCREW M2.5X6L K BZ ICT NY	6-35-B2125-6RA	
16	PRODUCT LABEL FOR W840SU-T	6-45-W840SU03-010	
16	PRODUCT LABEL FOR W840SU	6-45-W840SU03-010	
17	FRONT PANEL (OPTION) FOR W840SU-T	6-85-D40C2-L02	(OPTION)
17	FRONT PANEL (OPTION) FOR W840SU-T	6-85-D40C8-L01	(OPTION)
18	FRONT PANEL (OPTION) FOR W840SU-T	6-23-22015-TC1	
19	FRONT PANEL (OPTION) FOR W840SU-T	6-23-7W840-021	FOR W840SU-T
19	FRONT PANEL (OPTION) FOR W840SU-T	6-23-7W840-030	FOR W840SU
20	W/D HDD ASS'Y W840SU-T	6-79-W840SUJ-010	
20	W/HDD ASS'Y W840SU-T	6-79-W840SUJ-020	
21	HDD COVER MODULE W840SU-T	6-42-W840J-101	
22	BOTTOM BKT-A SECC W840SU-T	6-33-W8403-010	
23	SCREW M2X2L KI BK/Z ICT NY(M3.L1-86)	6-35-B6120-2RE	

# HDD



Figure A - 3  
HDD

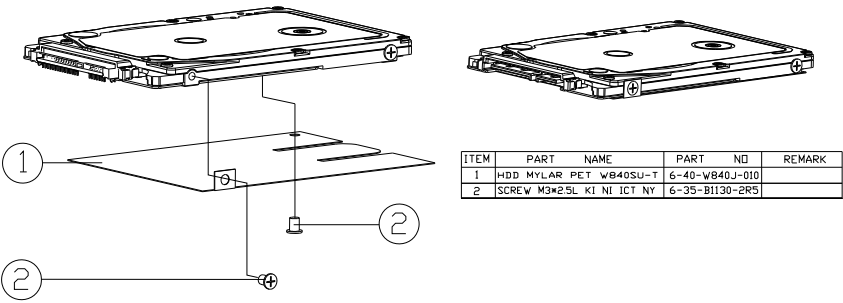

ITEM	PART NAME	PART NO	REMARK
1	HDD MYLAR PET WB40SU-T	6-40-WB40J-010	
2	SCREW M3*2.5L KI NI ICT NY	6-35-B1130-2R5	



# LCD

Figure A - 4  
LCD

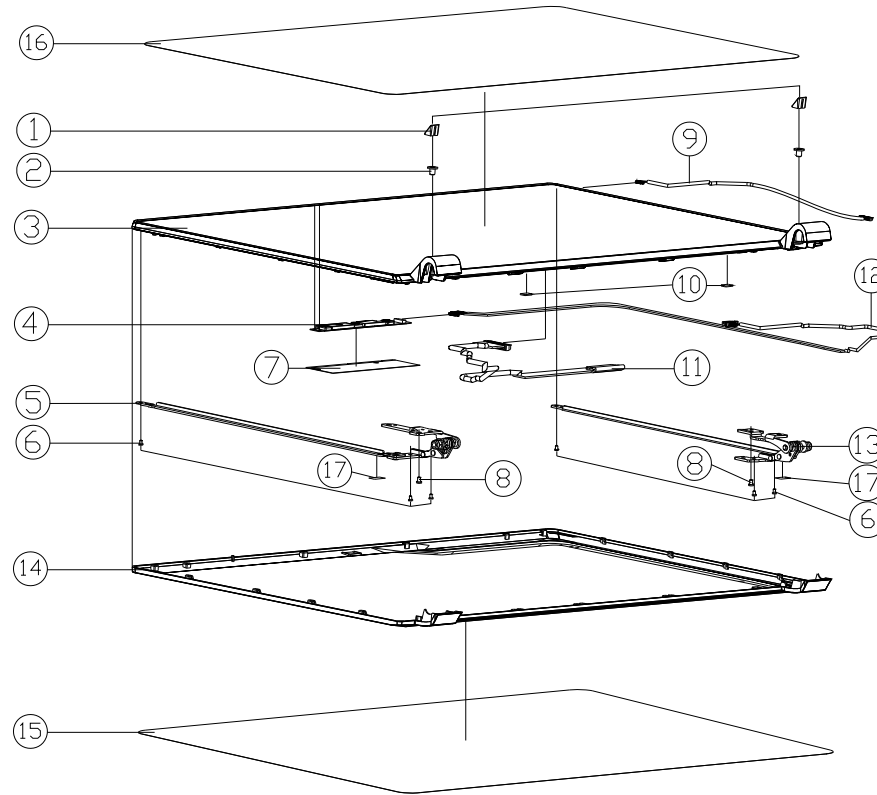

ITEM	PART NAME	PART NO	REMARK
1	LCD FRONT COVER SCREW RUBBER SILICON W840SN	6-47-W8401-011	
2	SCREW M2*SL K1CT-08 D=4.0 BK/Z ICT NY	6-35-B6120-5R0	
3	LCD RAY IN IN POLYMER/EP-THICK FILM/ADHESIVE/CLD FRONT CASE PLATE 1 (0.020)	6-50-W8401-G11	
3	LCD RAY IN IN POLYMER/EP-THICK FILM/ADHESIVE/CLD FRONT CASE PLATE 2 (0.020)	6-50-W8401-G21	
3	LCD RAY IN IN POLYMER/EP-THICK FILM/ADHESIVE/CLD FRONT CASE PLATE 3 (0.020)	6-50-W8401-H21	
3	LCD RAY IN IN POLYMER/EP-THICK FILM/ADHESIVE/CLD FRONT CASE PLATE 4 (0.020)	6-50-W8401-H30	
3	LCD RAY IN IN POLYMER/EP-THICK FILM/ADHESIVE/CLD FRONT CASE PLATE 5 (0.020)	6-50-W8401-D10	
4	MC CABLE FROM TO MICROWAVE IN IN FROM FROM BOTTOM W840SN W840SN	6-88-W740C-4901	
5	LCD HINGE L (SK7-DIE-CASTING+SUS430) W840SU-T	6-33-W8401-0L1	
6	SCREW M2*SL K1 BK/Z ICT NY (0.35 L=0.3)	6-35-B6120-3RE	
7	CCD SHIELDING (AL FOIL+GASKET) W840SU-T	6-47-W8401-031	
8	SCREW M2.5*SL HWH 0.4MM K1 BK/Z ICT NY	6-35-B6125-5R0	
9	WIRE CABLE FOR CONTROLLER BOARD TO MB SPIN W840SU-T (0L)	6-43-W8400-051	
10	GASKET (12*10*2) FOR TOP CASE W740S	6-47-00190-12Q	
11	WIRE CABLE FOR LCD TO MB SPIN (LPA/LC CONDUCTOR) W840SU-T	6-43-W8401-011-K	FOR eDP CONN
11	WIRE CABLE FOR LCD TO MB SPIN (LVDS CONDUCTOR) W840SU-T	6-43-W8401-021-K	FOR LVDS CONN
12	WIRE CABLE CCD+MIC TO MB SPIN W840SU-T (0L)	6-43-W840T-011	
13	LCD HINGE R (SK7-DIE-CASTING+SUS430) W840SU-T	6-33-W8401-0R1	
14	LCD BACK COVER MODULE W840SN	6-39-W8401-021	
15	LCD BACK COVER PROTECT MYLAR PET W740SU	6-40-W7401-010	
16	TOUCH GLASS PROTECTION FILM PET W840SU-T	6-40-W8401-010	
17	TP80V (L9*W5) FOR MB BOTTOM TP80V	6-47-T80VS-020	

# Appendix B: Schematic Diagrams

This appendix has circuit diagrams of the *W840SN* notebook's PCB's. The following table indicates where to find the appropriate schematic diagram.

Diagram - Page	Diagram - Page	Diagram - Page
<i>System Block Diagram - Page B - 2</i>	<i>VGA PCI-E Interface - Page B - 17</i>	<i>Charger, DC In - Page B - 32</i>
<i>Processor 1/11 - Page B - 3</i>	<i>VGA Frame Buffer Interface - Page B - 18</i>	<i>1.05V - Page B - 33</i>
<i>Processor 2/11 - Page B - 4</i>	<i>VGA Frame Buffer A - Page B - 19</i>	<i>VDD3, VDD5 - Page B - 34</i>
<i>Processor 3/11 - Page B - 5</i>	<i>VGA Frame Buffer B - Page B - 20</i>	<i>1.8VS, 1.5VS, 5V, 5VS, SATA_5VS - Page B - 35</i>
<i>Processor 4/11 - Page B - 6</i>	<i>VGA I/O - Page B - 21</i>	<i>DDR 1.5V or 1.35V / 0.75VS PCH 1.5VS - Page B - 36</i>
<i>Processor 5/11 - Page B - 7</i>	<i>VGA NVVDD Decoupling - Page B - 22</i>	<i>VCORE - Page B - 37</i>
<i>Processor 6/11 - Page B - 8</i>	<i>PS8625 - Page B - 23</i>	<i>N14P, NVVDD, PEX, FBVDDQ - Page B - 38</i>
<i>Processor 7/11 - Page B - 9</i>	<i>Card Reader / LAN RTL8411B - Page B - 24</i>	<i>Audio Board - Page B - 39</i>
<i>Processor 8/11 - Page B - 10</i>	<i>WLAN, MSATA - Page B - 25</i>	<i>HDD Board - Page B - 40</i>
<i>Processor 9/11 - Page B - 11</i>	<i>HDMI, RJ45, Fan - Page B - 26</i>	<i>Click Board - Page B - 41</i>
<i>Processor 10/11 - Page B - 12</i>	<i>Audio Codec ALC282 - Page B - 27</i>	<i>LED Board - Page B - 42</i>
<i>Processor 11/11 - Page B - 13</i>	<i>USB Charger, USB, LED - Page B - 28</i>	<i>Power Sequence - Page B - 43</i>
<i>DDR3 SO-DIMM_0 - Page B - 14</i>	<i>KBC-ITE IT8587 - Page B - 29</i>	
<i>DDR3 SO-DIMM_1 - Page B - 15</i>	<i>CCD, TPM, I/O Connector, LID - Page B - 30</i>	
<i>PANEL, INVERTER - Page B - 16</i>	<i>KBC-ITE IT8587E - Page B - 31</i>	

*Table B - 1*  
**SCHEMATIC  
DIAGRAMS**



**Version Note**

The schematic diagrams in this chapter are based upon version 6-7P-W8405-003. If your mainboard (or other boards) are a later version, please check with the Service Center for updated diagrams (if required).

# System Block Diagram

Sheet 1 of 42  
System Block  
Diagram

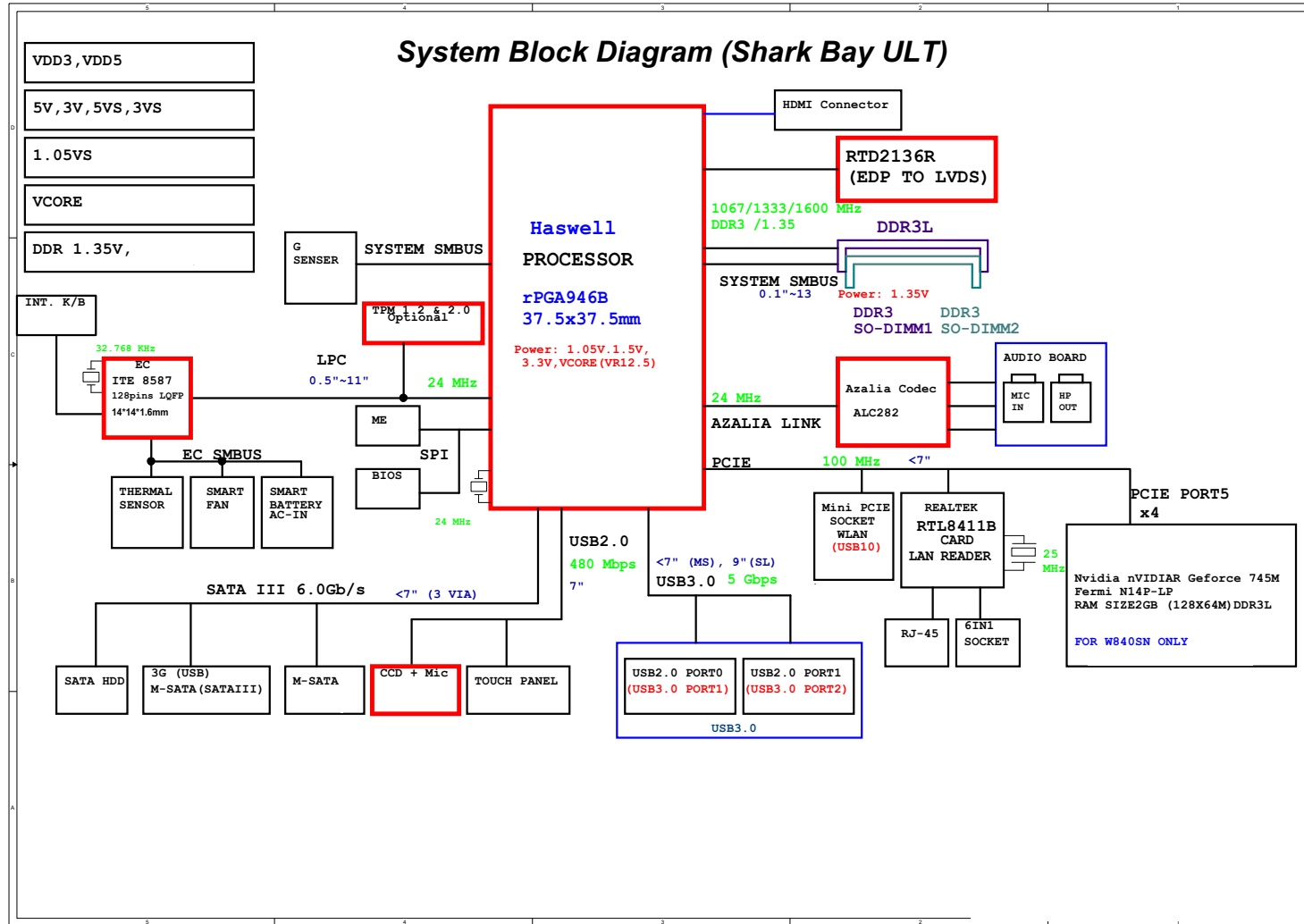

# Processor 1/11

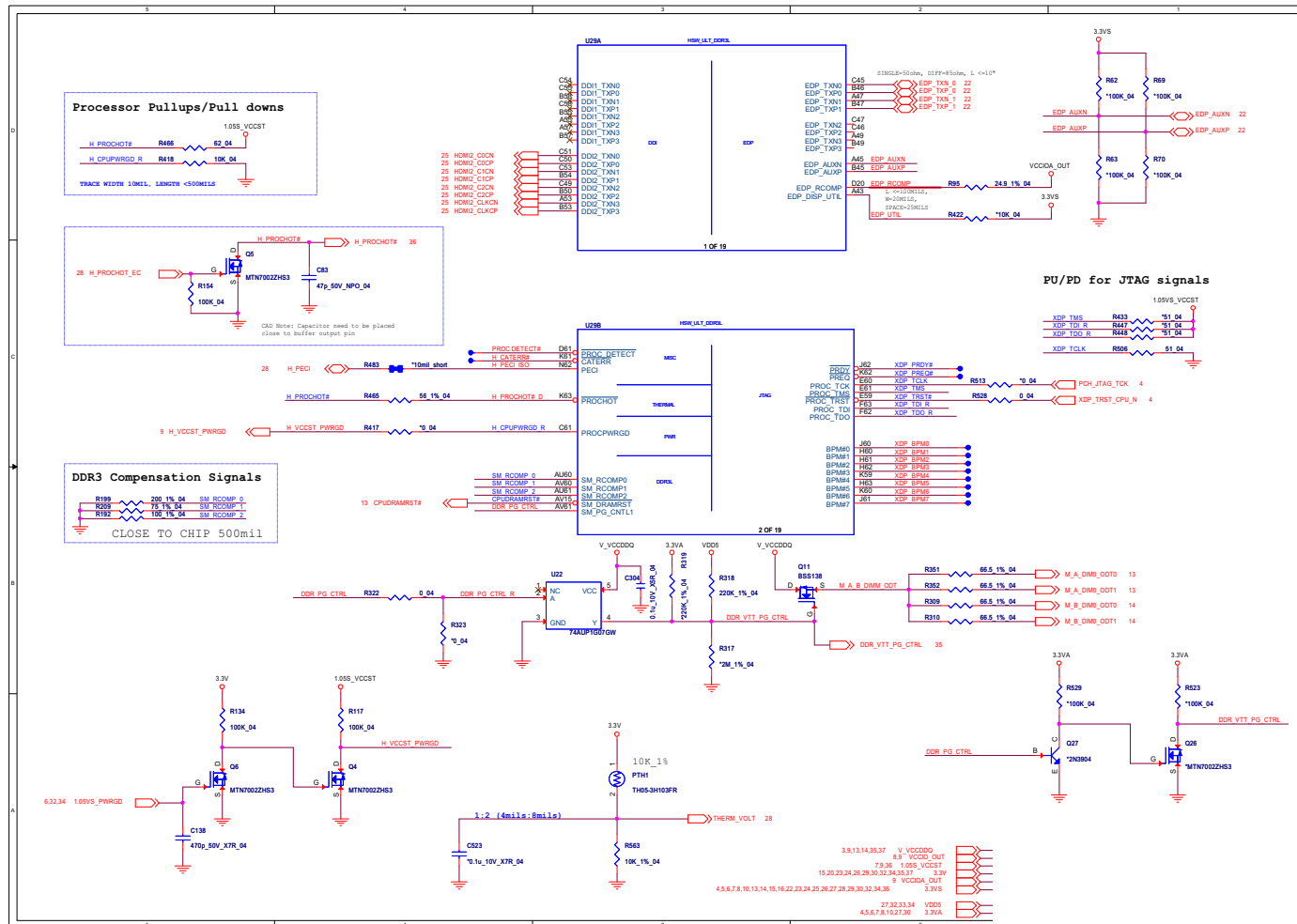

Sheet 2 of 42  
Processor 1/11

# Processor 2/11

Sheet 3 of 42  
Processor 2/11

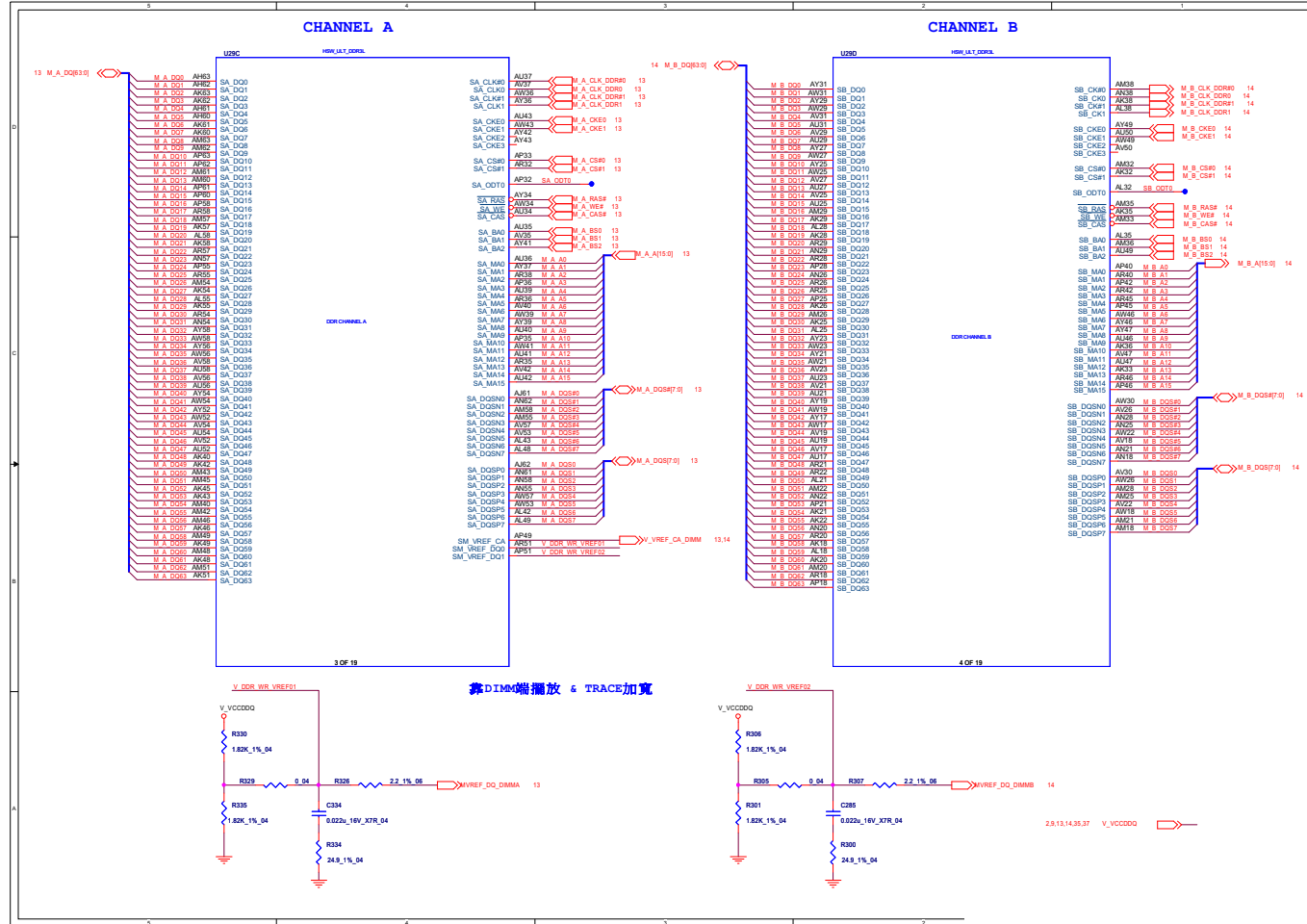



# Processor 3/11

Sheet 4 of 42  
Processor 3/11

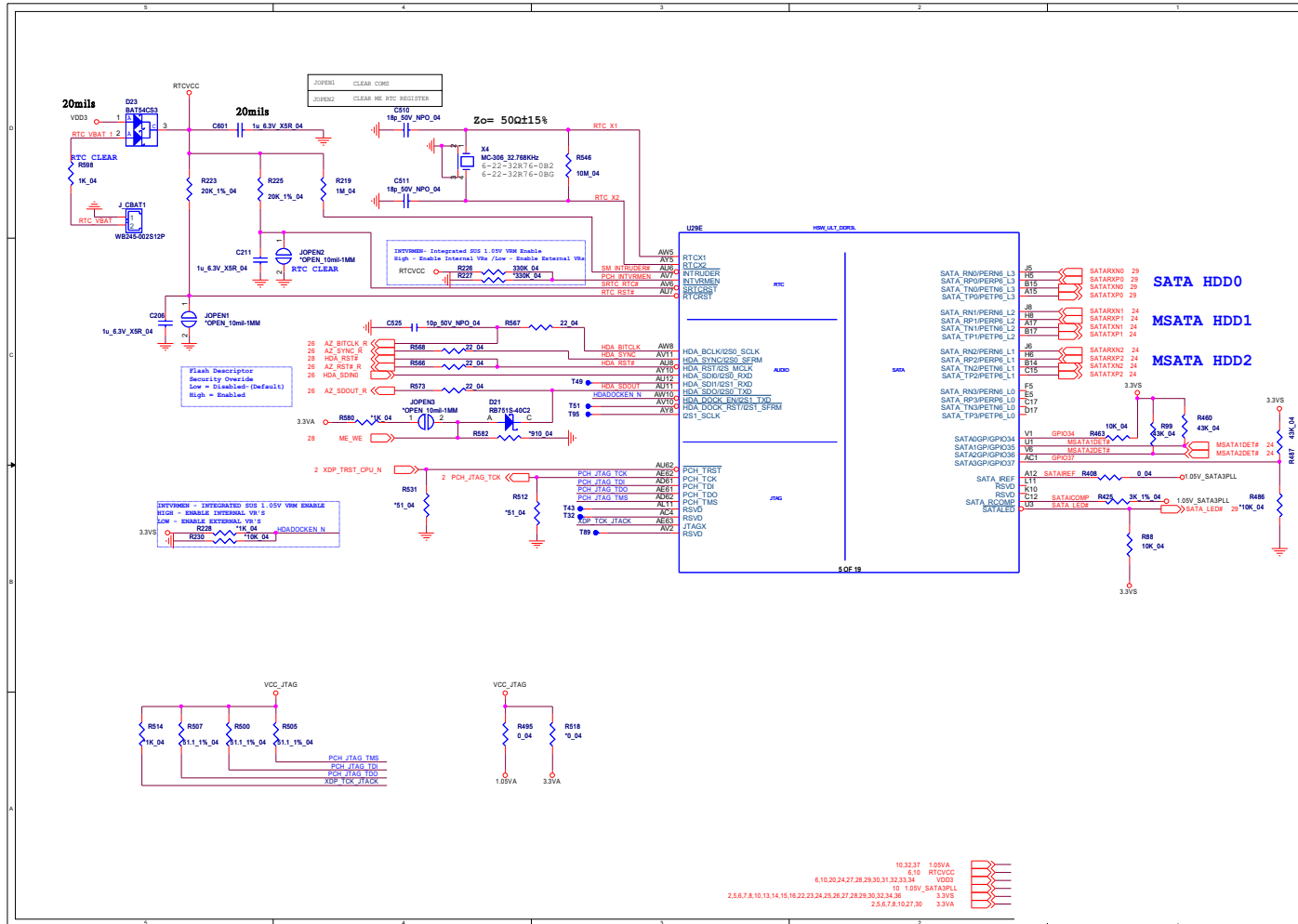

# Schematic Diagrams

## Processor 4/11

B.Schematic Diagrams

Sheet 5 of 42  
Processor 4/11

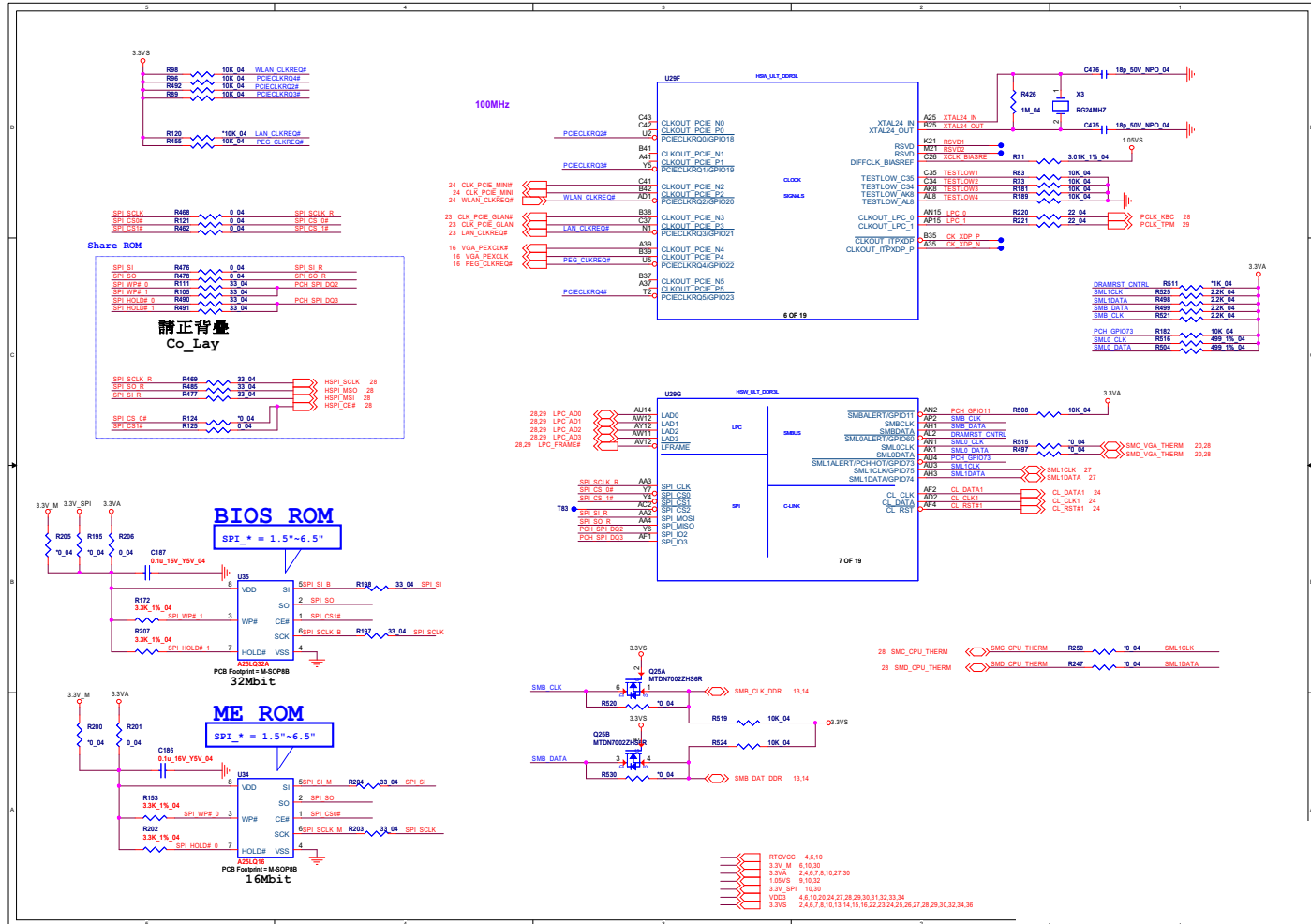

# Processor 5/11

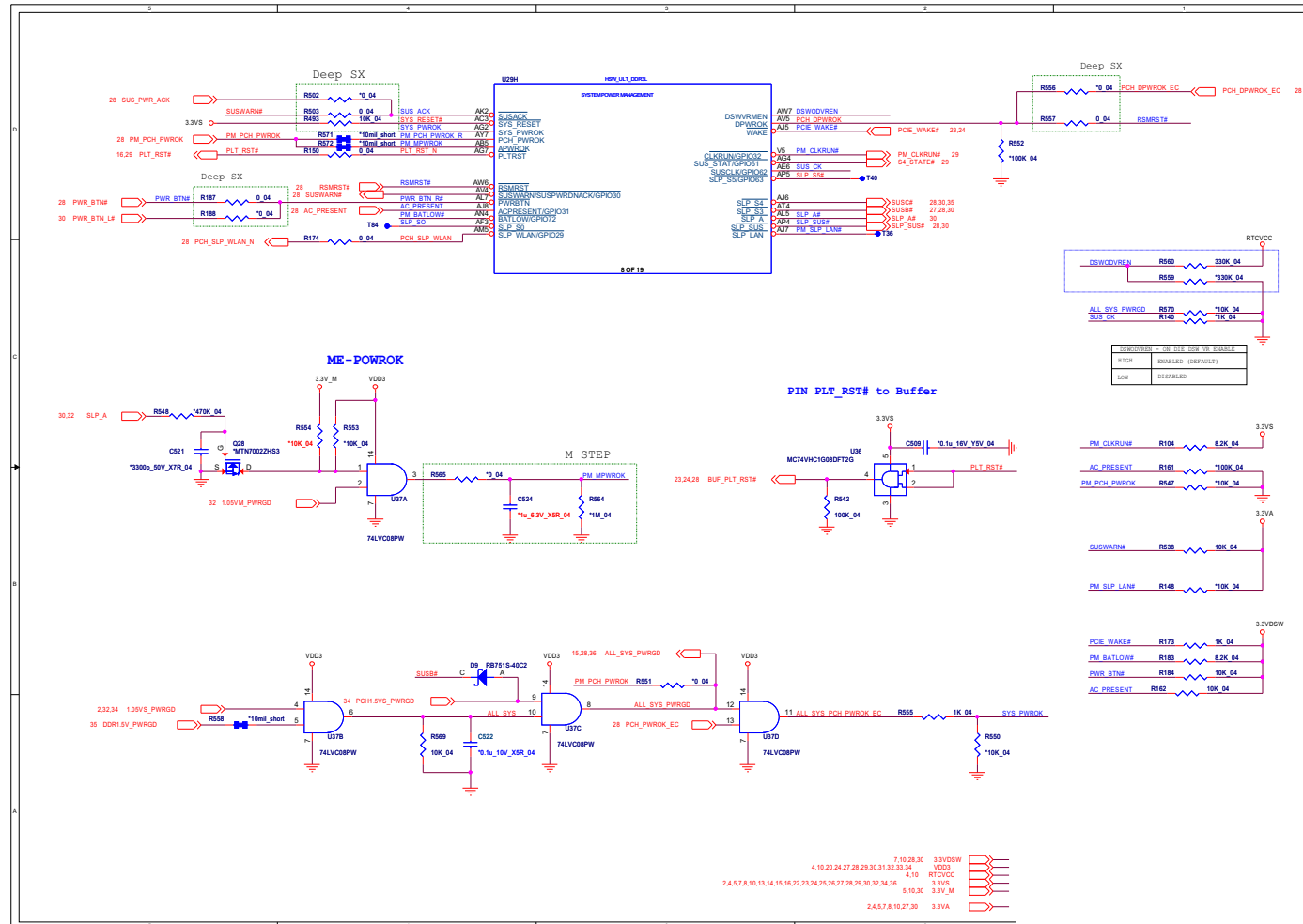

Sheet 6 of 42  
Processor 5/11

B.Schematic Diagrams

# Processor 6/11

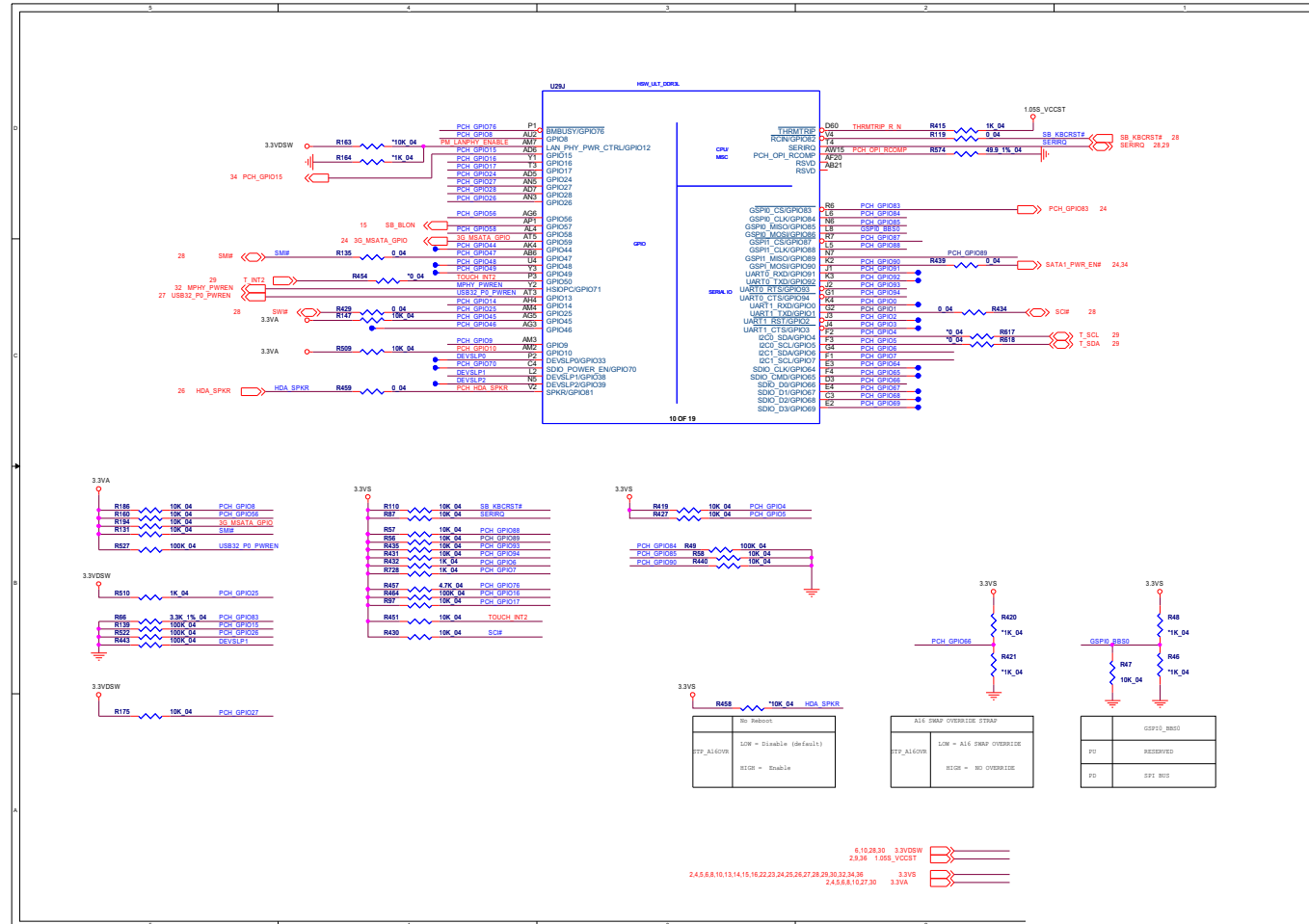

# Processor 7/11

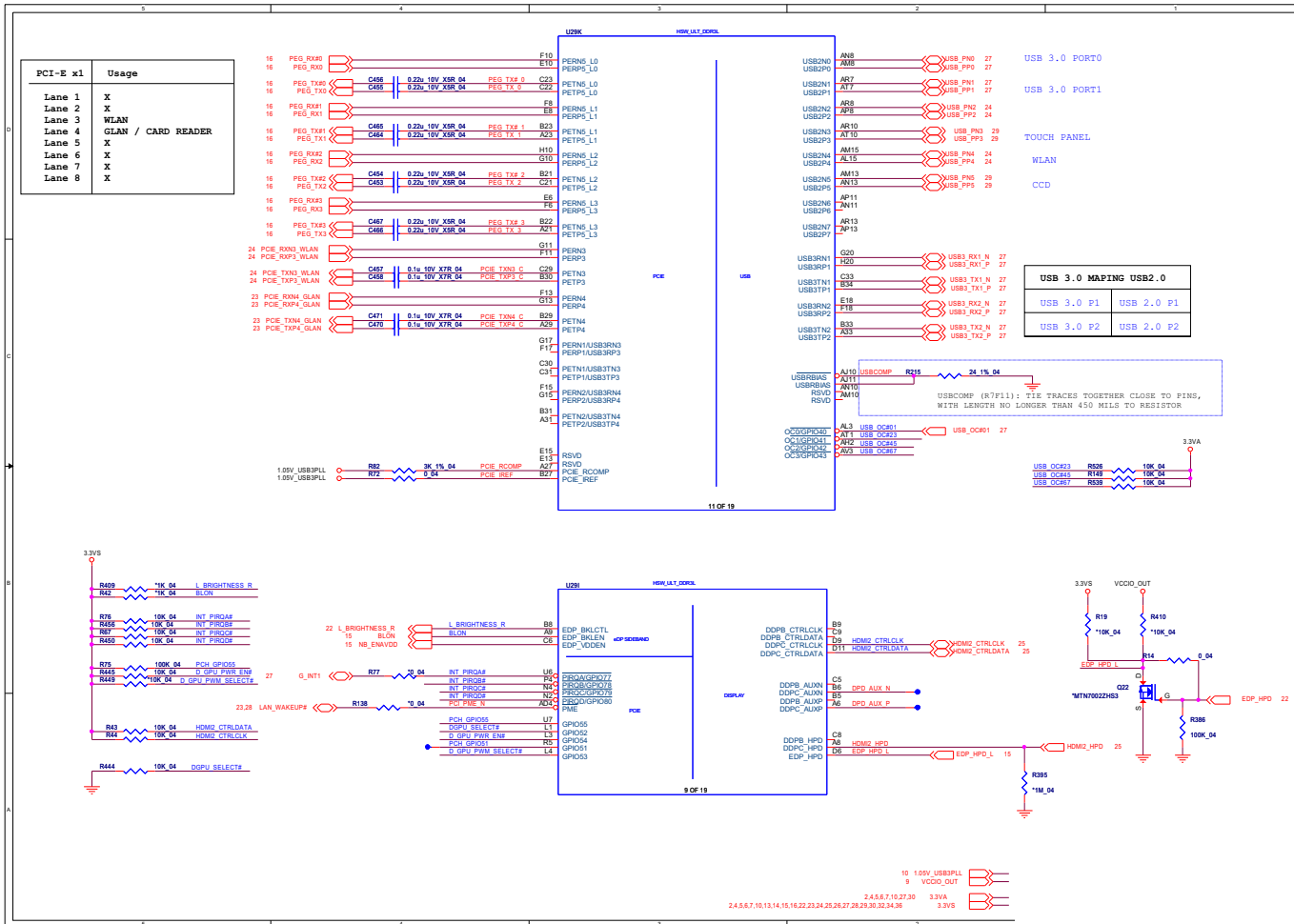

Sheet 8 of 42  
Processor 7/11

B.Schematic Diagrams

# Processor 8/11

Sheet 9 of 42  
Processor 8/11

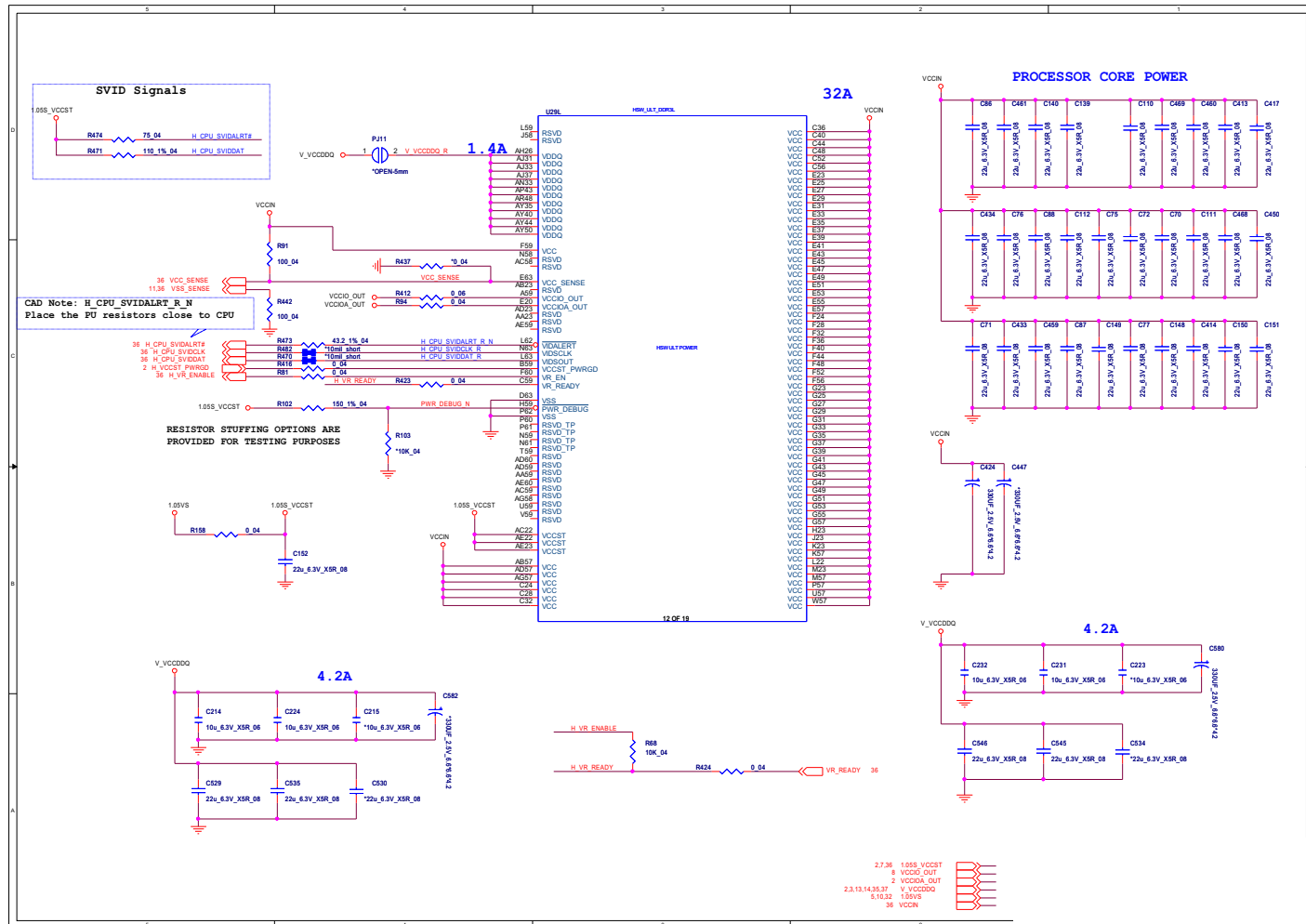

# Processor 9/11

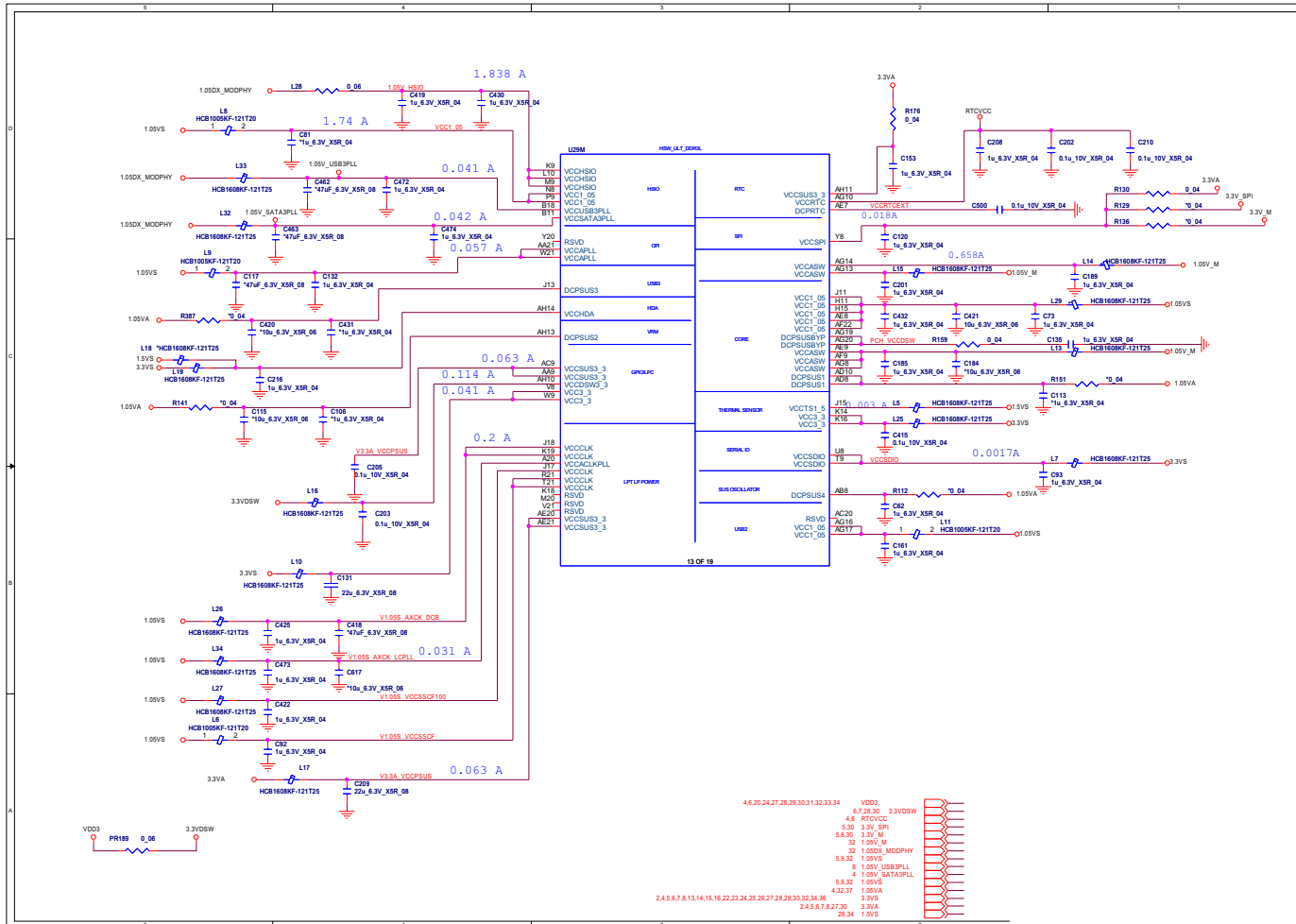

Sheet 10 of 42  
Processor 9/11

B.Schematic Diagrams

# Processor 10/11

Sheet 11 of 42  
Processor 10/11

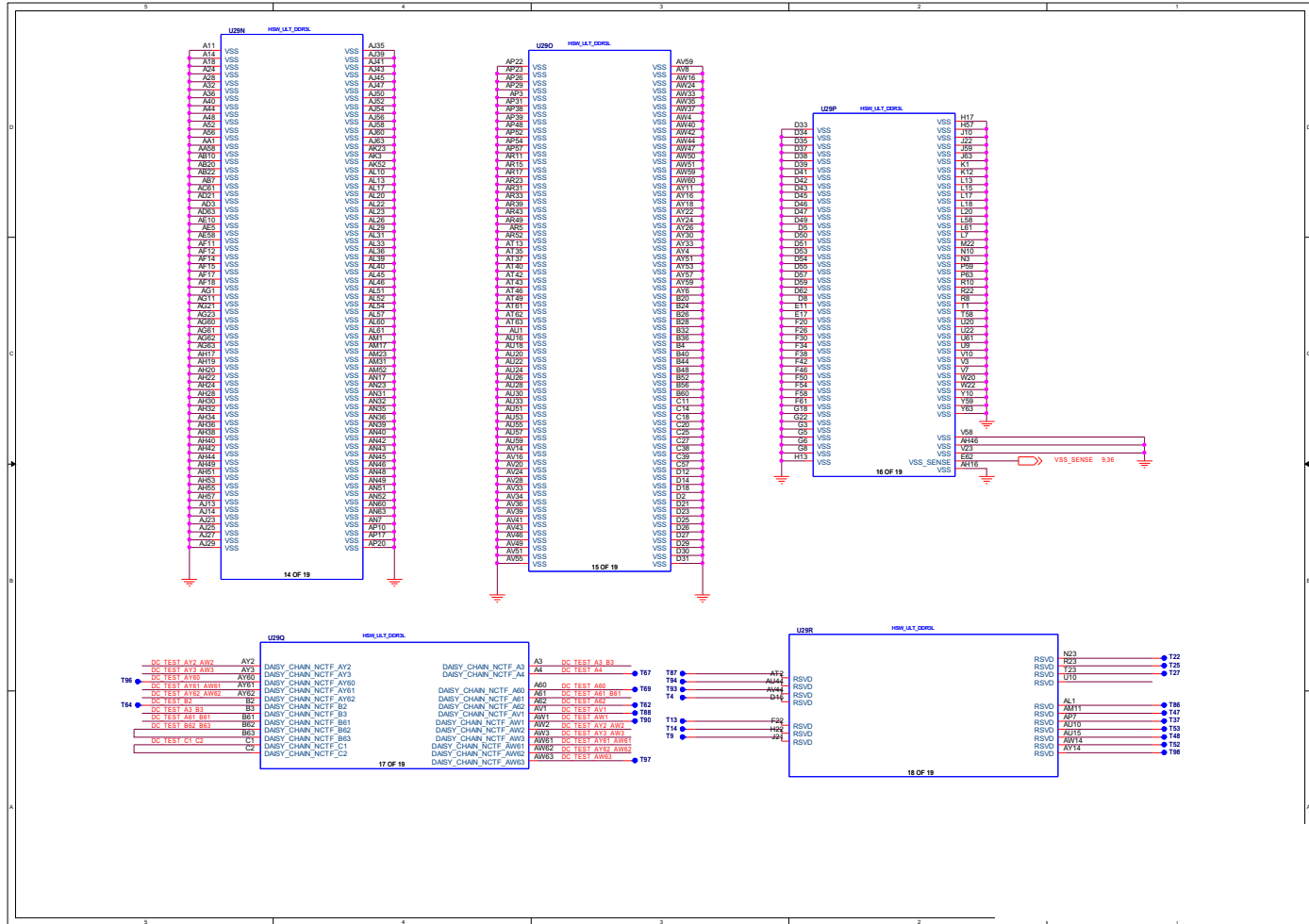



# Processor 11/11

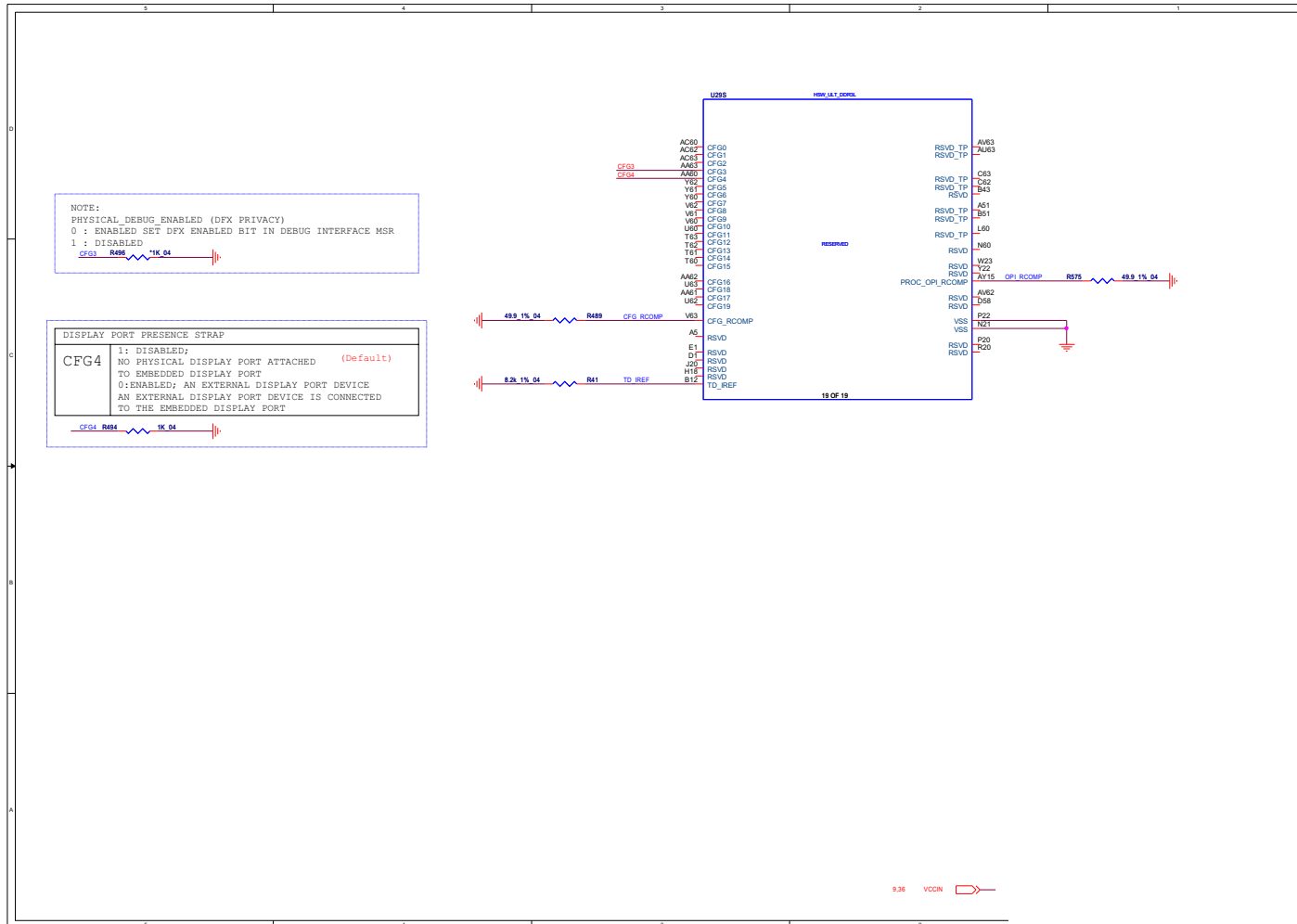

Sheet 12 of 42  
 Processor 11/11





# PANEL, INVERTER

Sheet 15 of 42  
PANEL, INVERTER

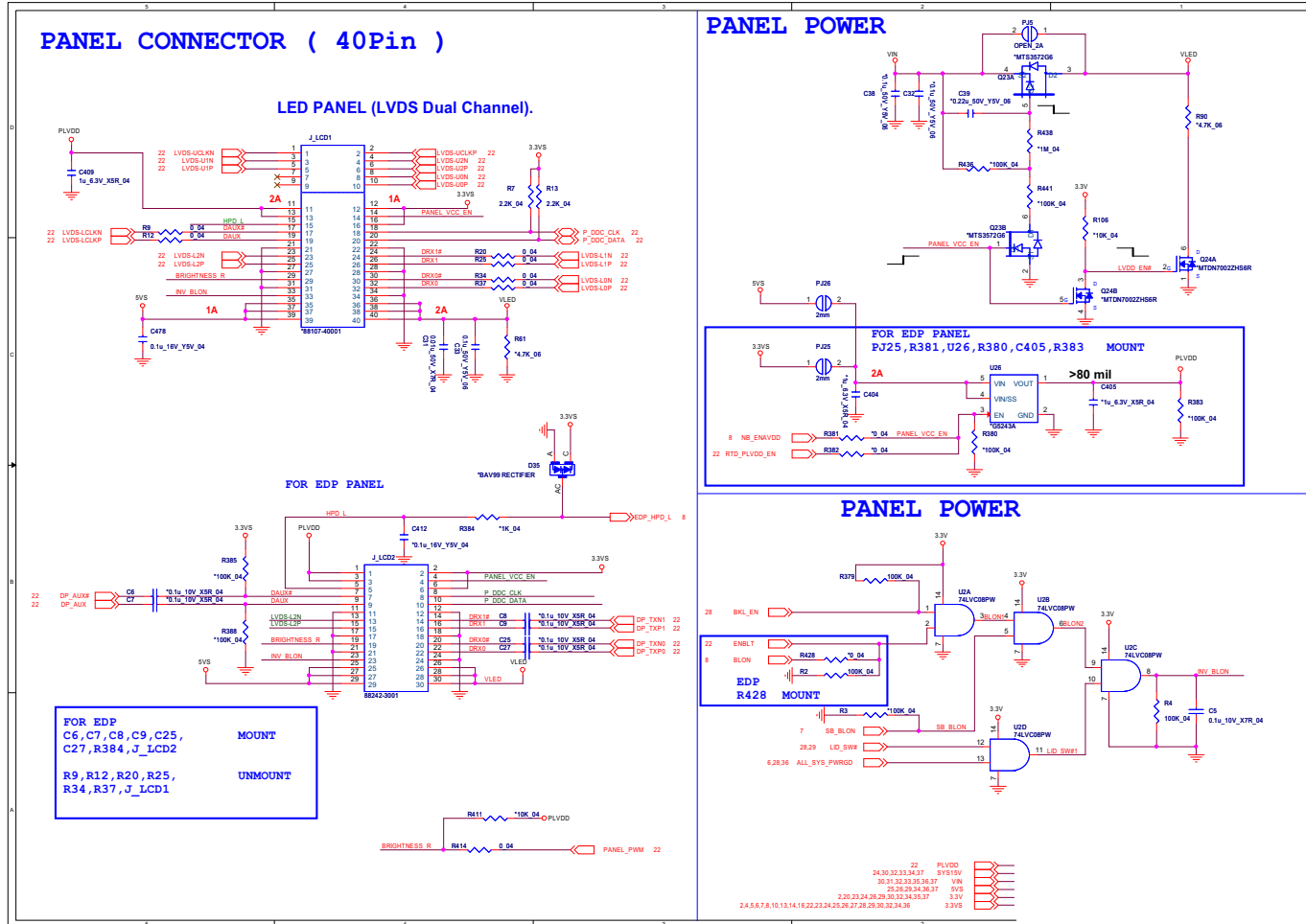

# VGA PCI-E Interface

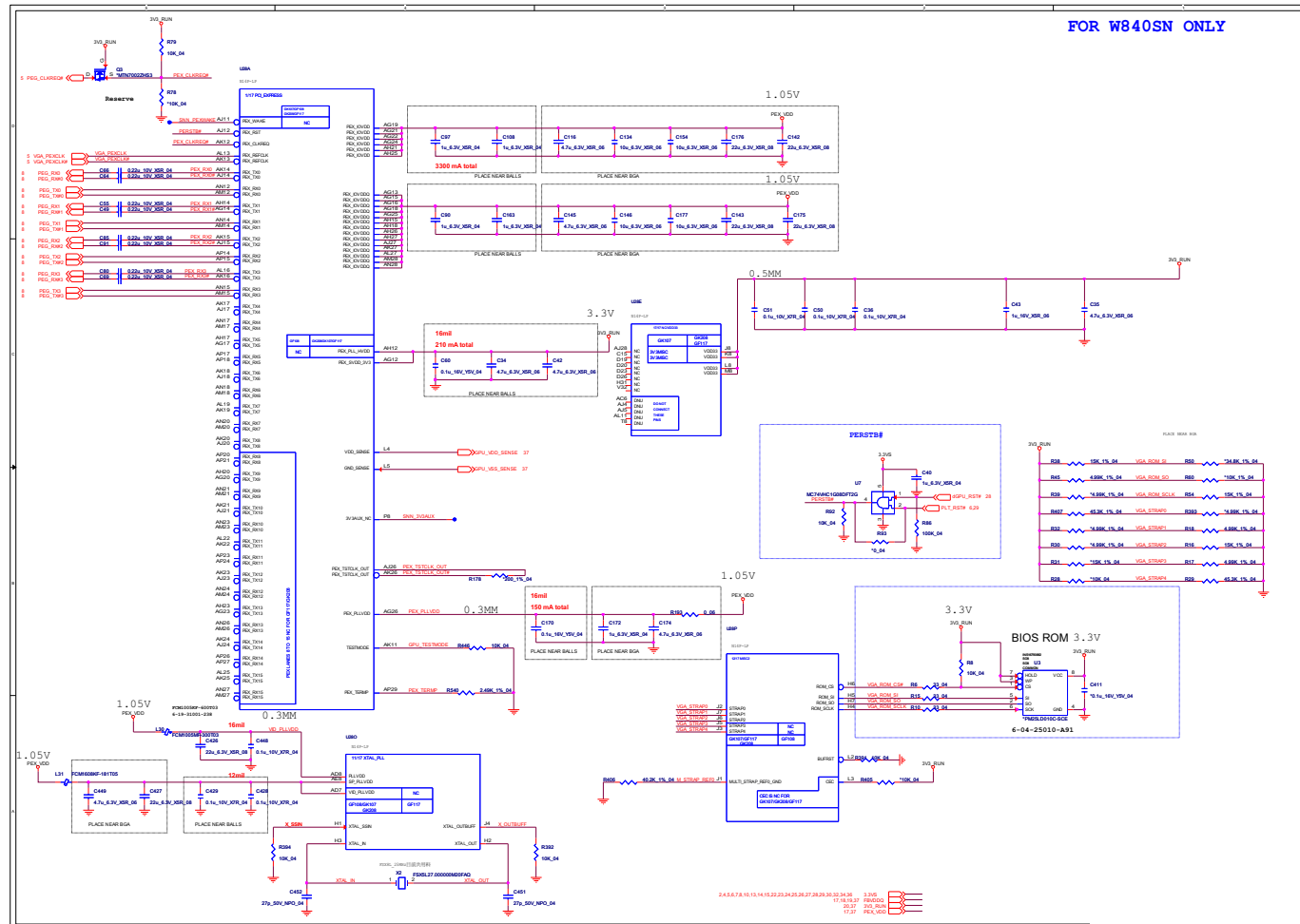

Sheet 16 of 42  
VGA PCI-E  
Interface

# VGA Frame Buffer Interface

Sheet 17 of 42  
VGA Frame Buffer Interface

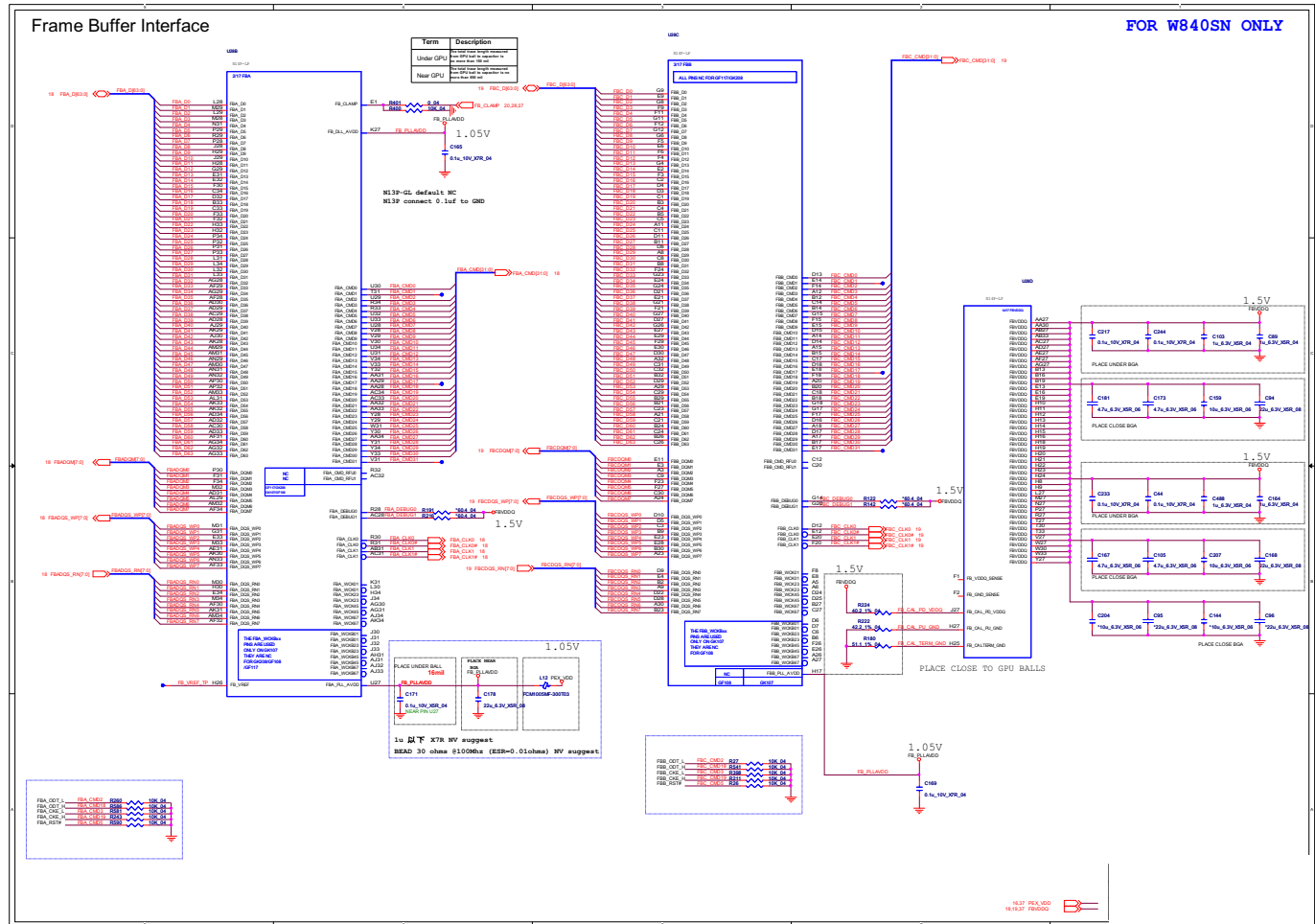

# VGA Frame Buffer A

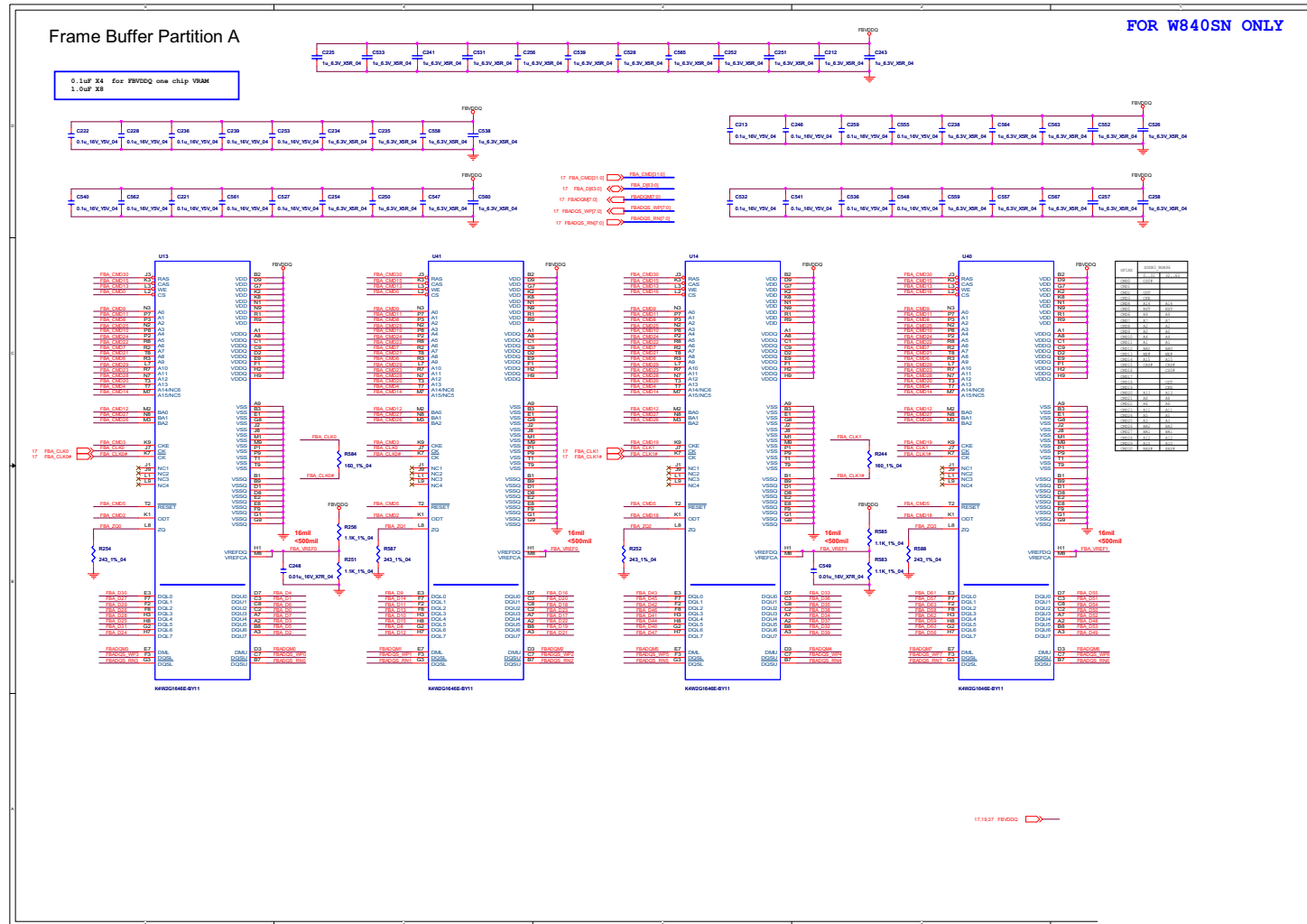

Sheet 18 of 42  
VGA Frame Buffer A





VGA I/O

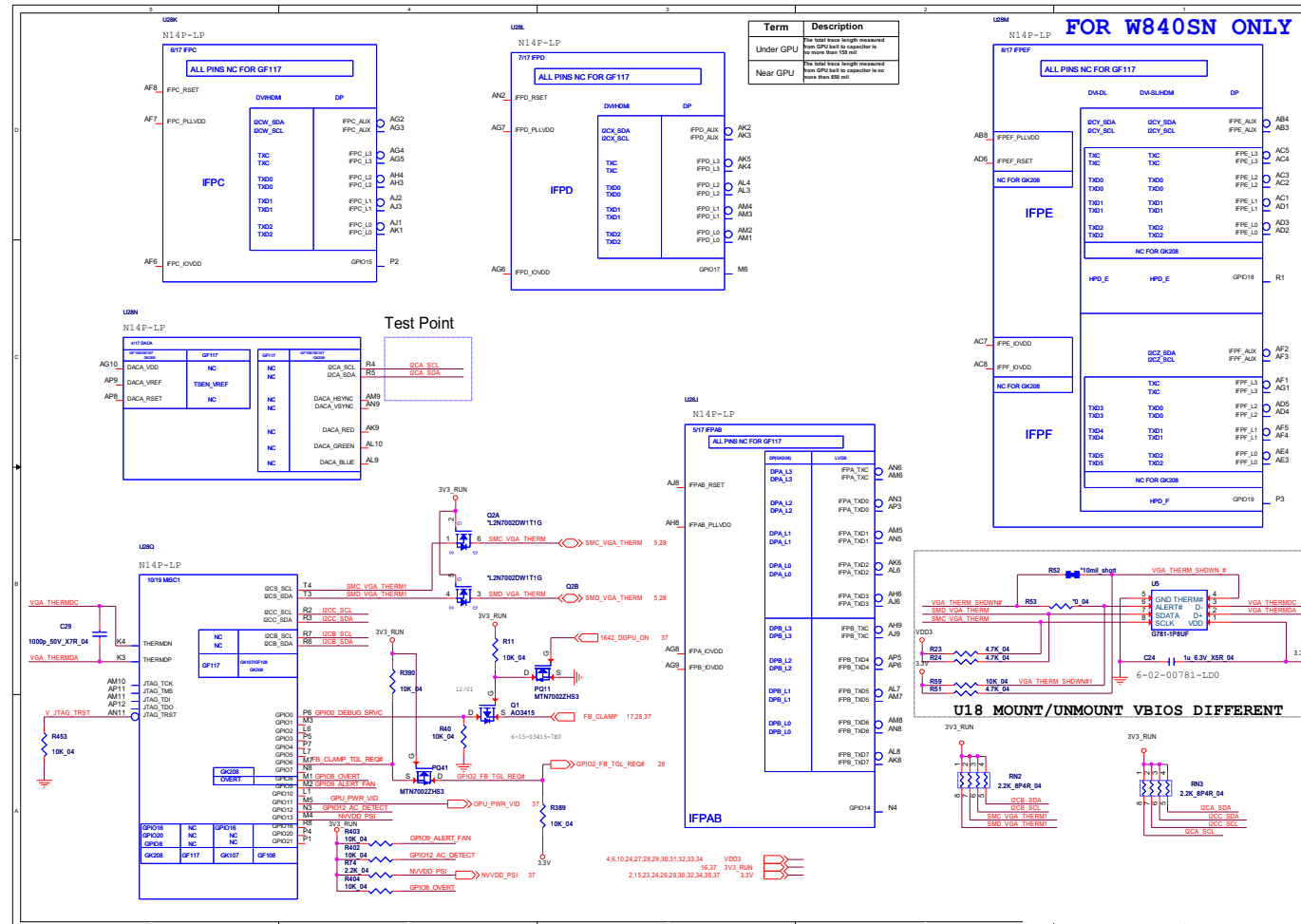

Sheet 20 of 42  
VGA I/O

B.Schematic Diagrams

# VGA NVVDD Decoupling

Sheet 21 of 42  
VGA NVVDD  
Decoupling

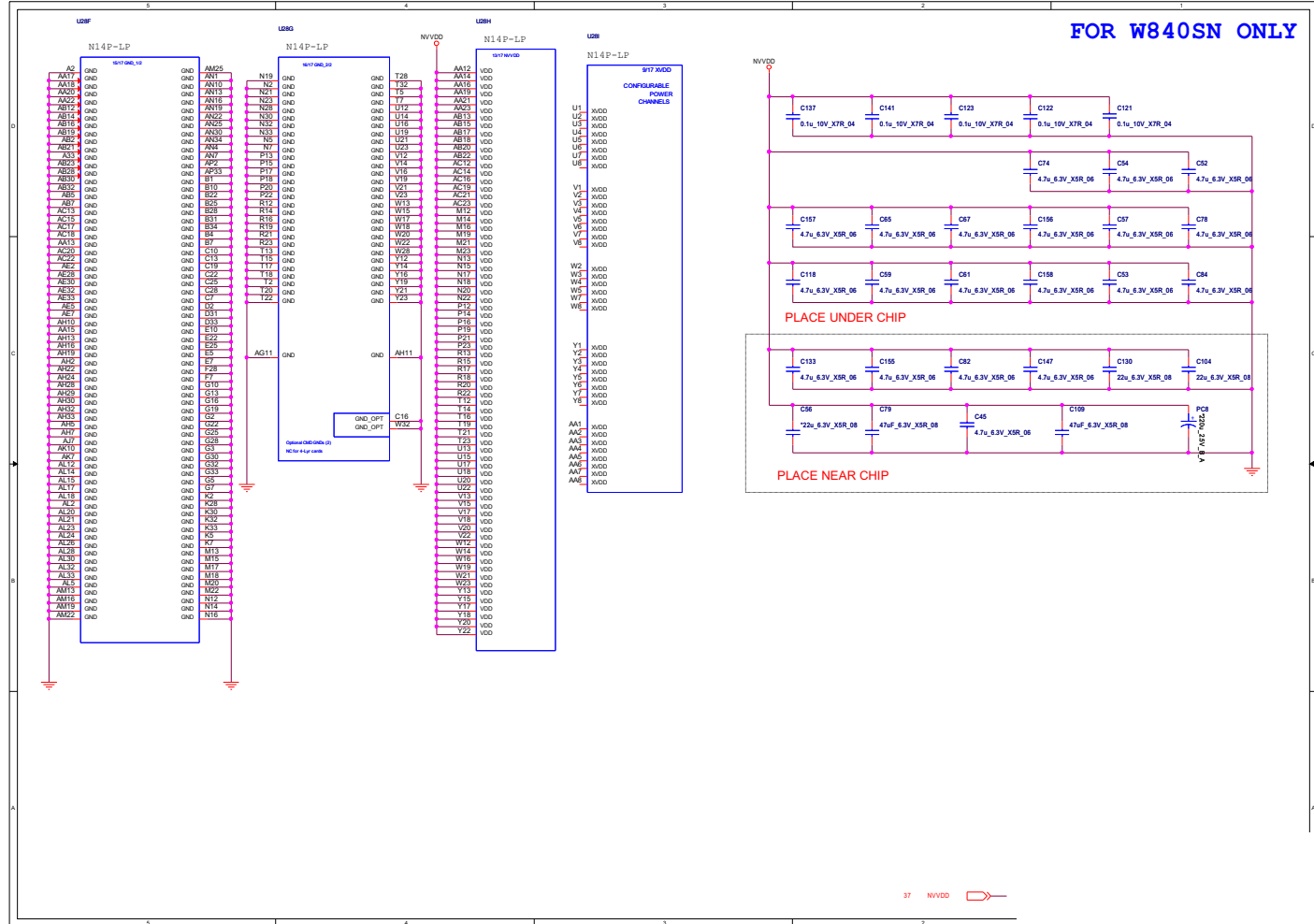

PS8625

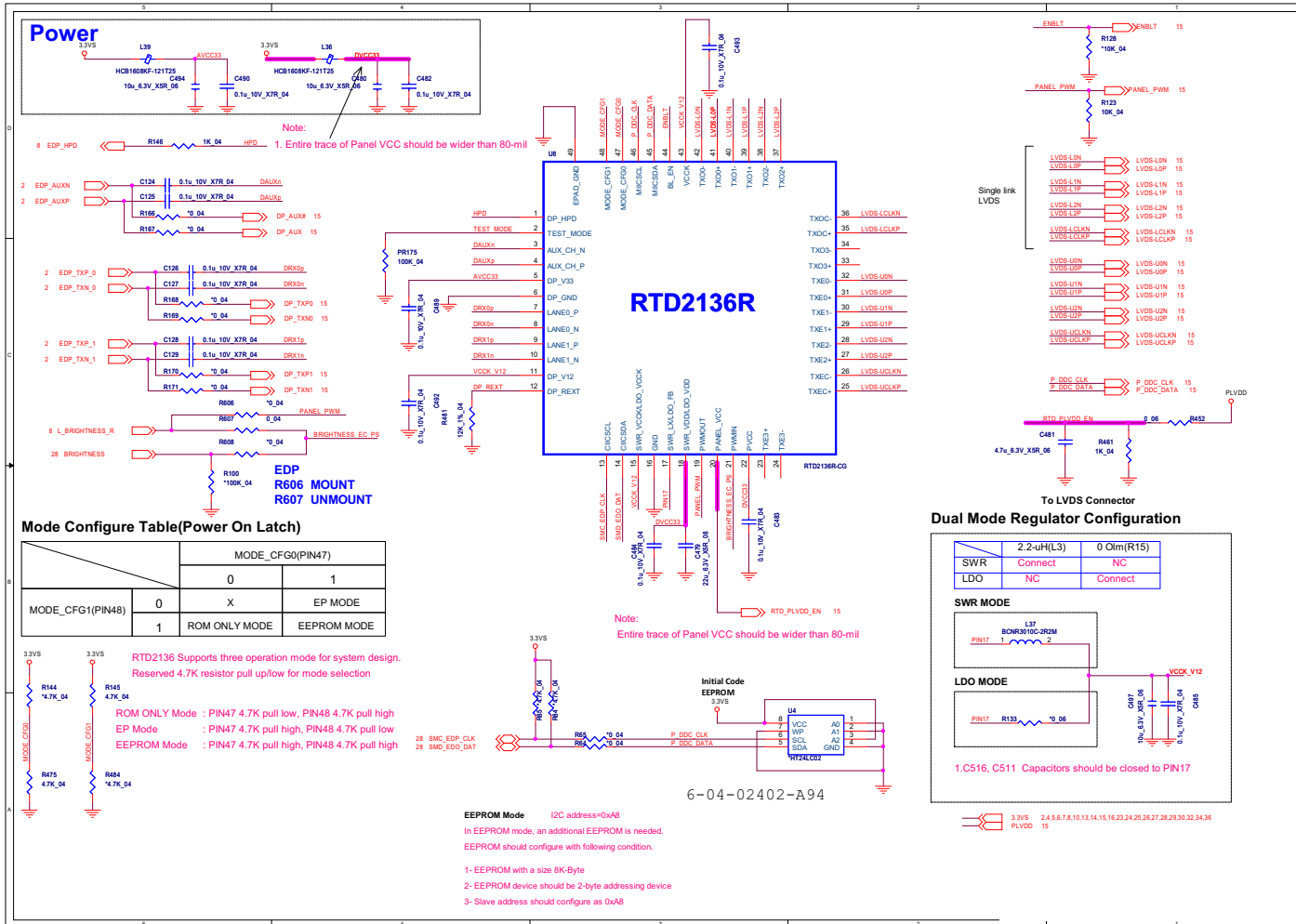

Sheet 22 of 42  
PS8625

# Card Reader / LAN RTL8411B

Sheet 23 of 42  
Card Reader /  
LAN RTL8411B

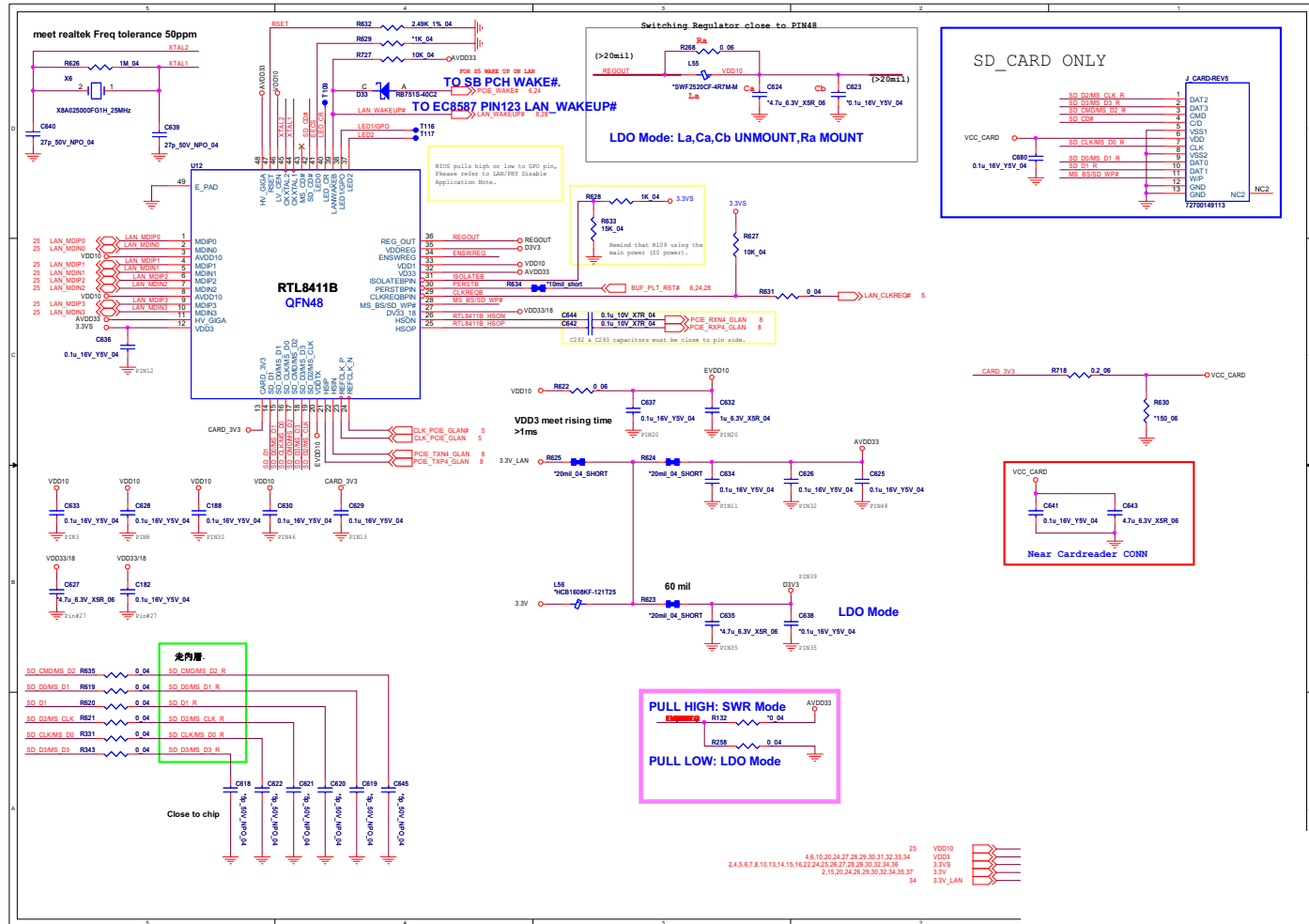

# WLAN, MSATA

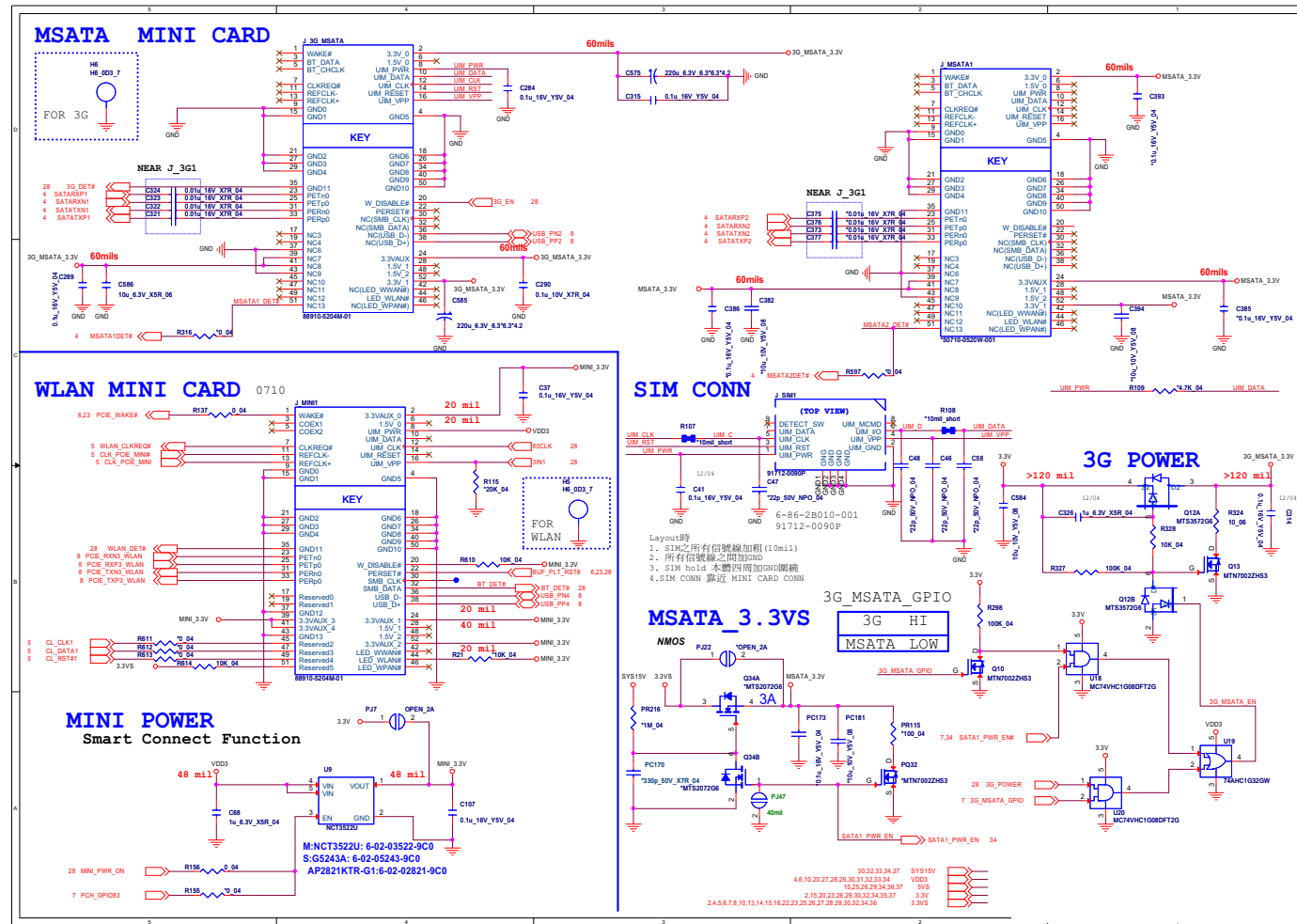

B.Schematic Diagrams

Sheet 24 of 42  
WLAN, MSATA

# HDMI, RJ45, Fan

B.Schematic Diagrams

Sheet 25 of 42  
HDMI, RJ45, Fan

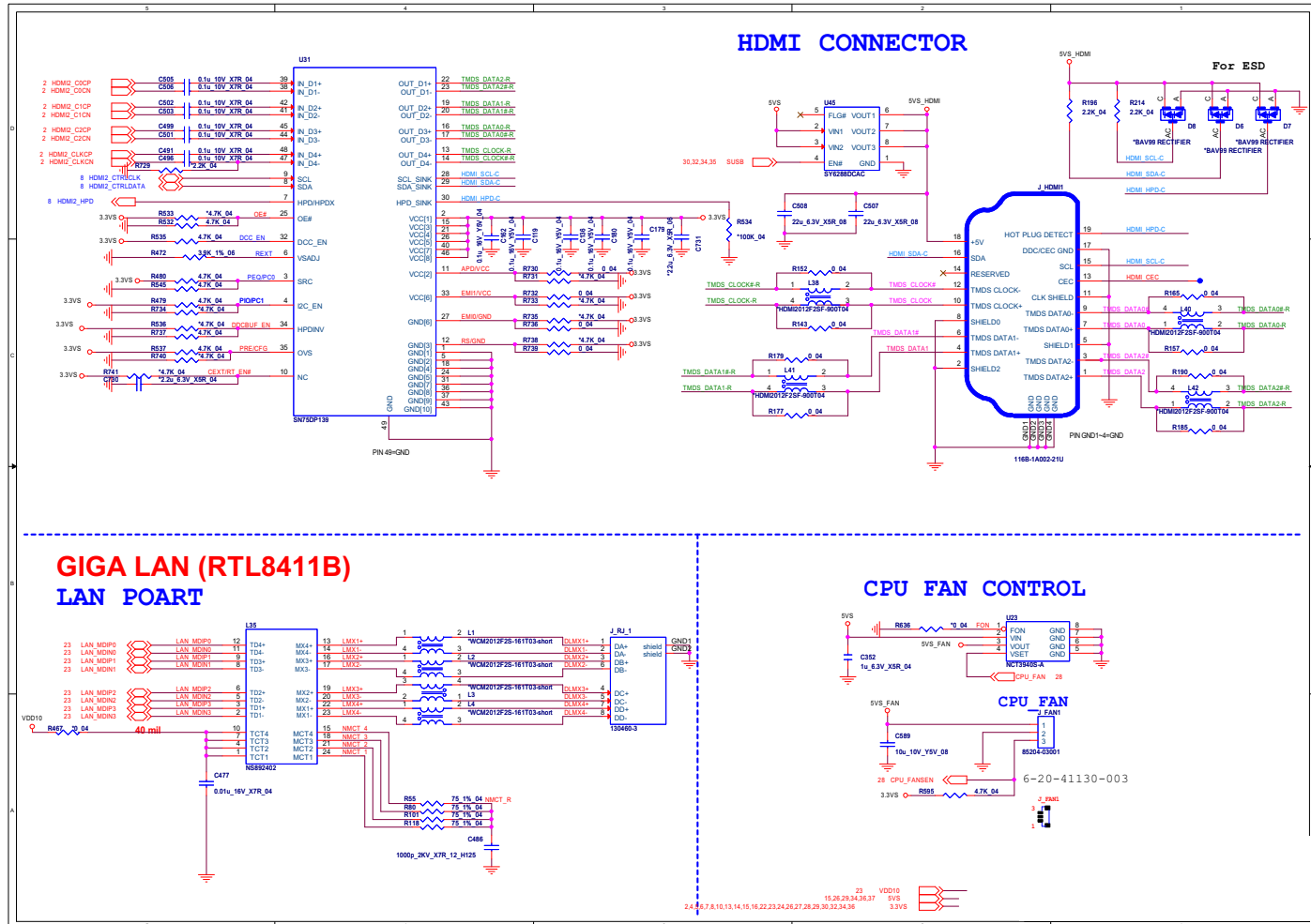

# Audio Codec ALC282

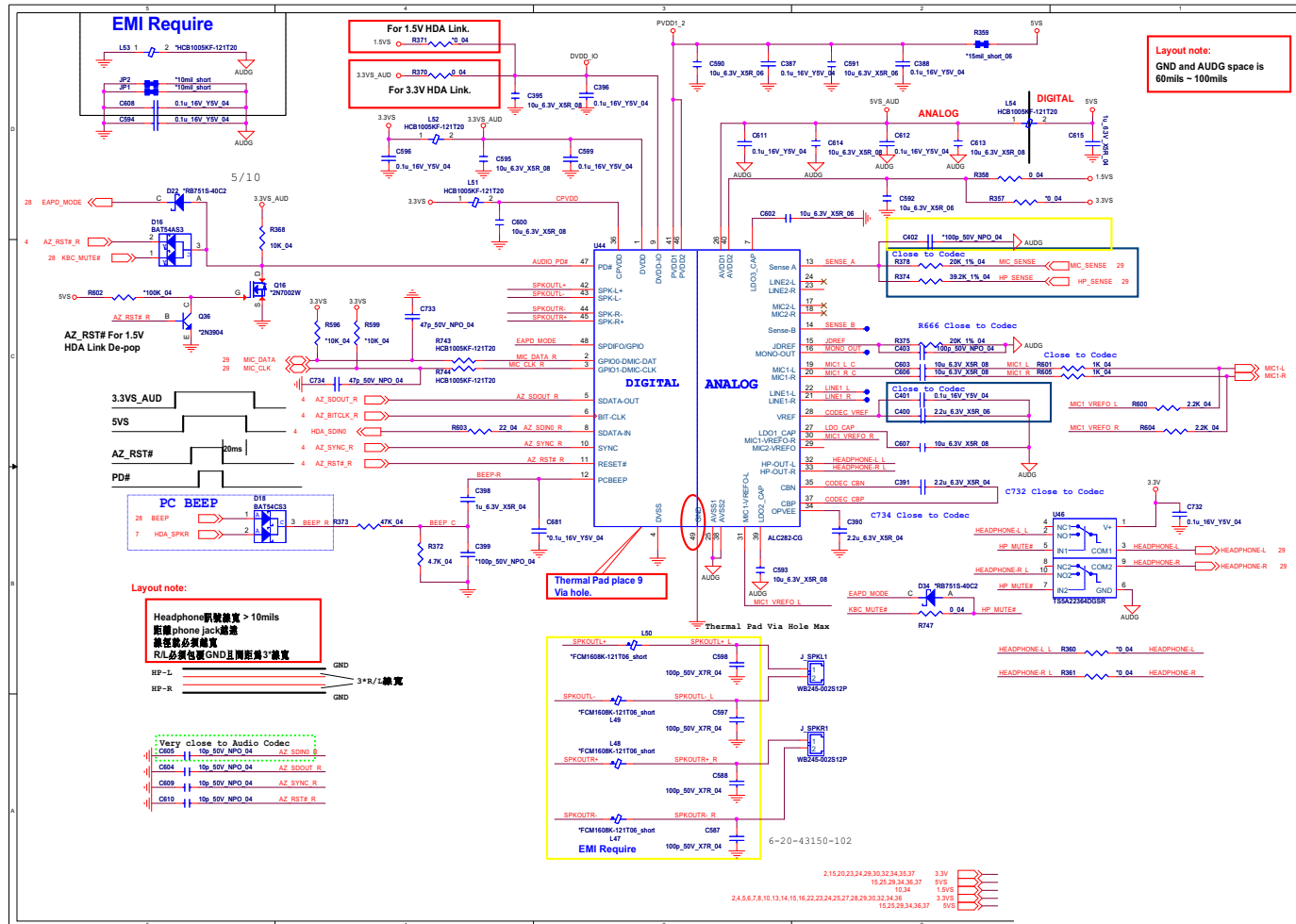

Sheet 26 of 42  
Audio Codec  
ALC282





## KBC-ITE IT8587

B.Schematic Diagrams

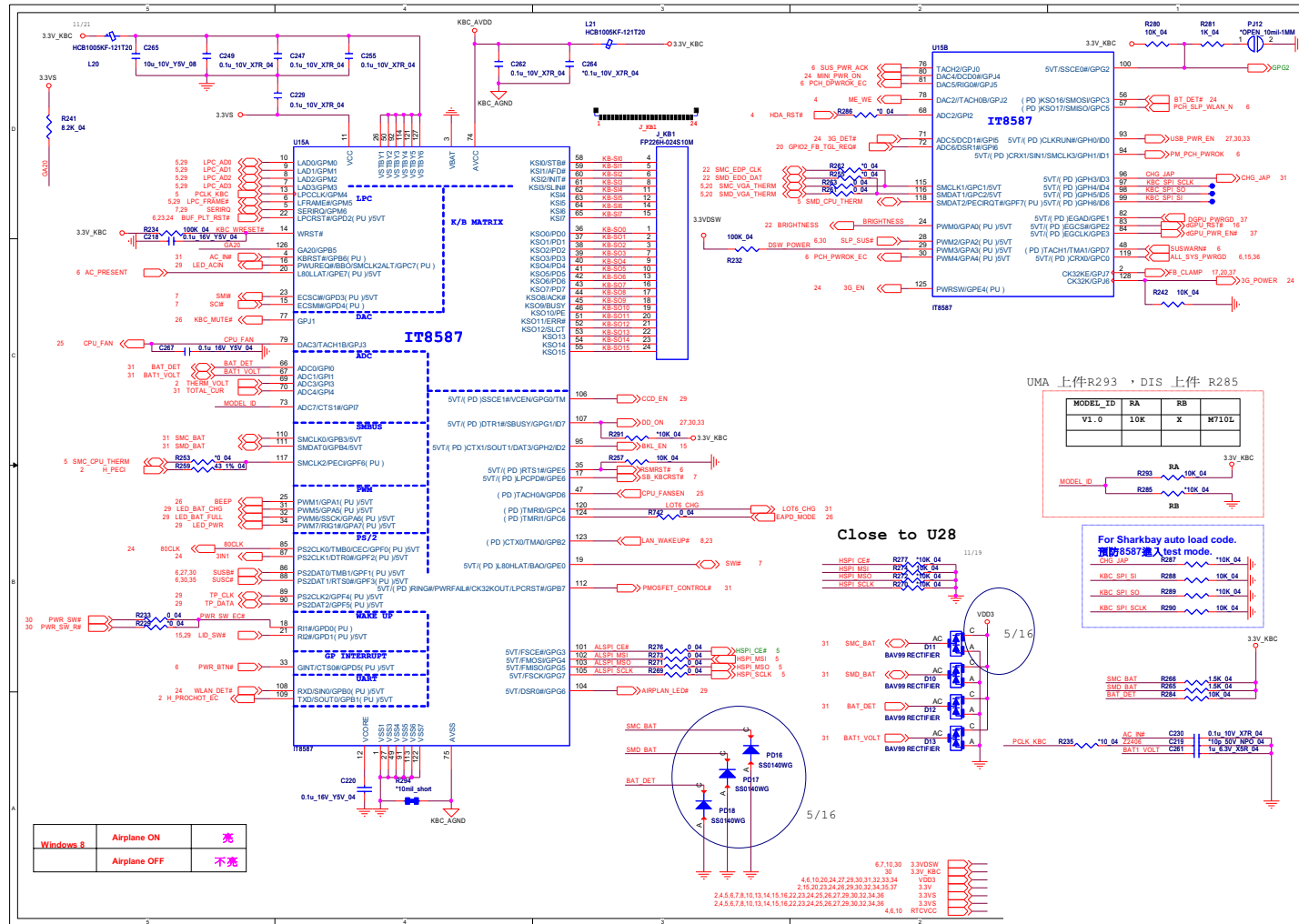

Sheet 28 of 42  
KBC-ITE IT8587

UMA 上件 R293 · DIS 上件 R285

MODEL_ID	RA	RB	M710L
V1.0	10K 04	X	

MODEL ID

R293	RA	10K 04
R285	RB	10K 04

For Sharkbay auto load code.  
預防8587進入test mode.

CHG_JAP	R287	10K 04
KBC_SPL_SI	R288	10K 04
KBC_SPL_SO	R289	10K 04
KBC_SPL_SCLK	R290	10K 04

# CCD, TPM, I/O Connector, LID

Sheet 29 of 42  
 CCD, TPM,  
 I/O Connector, LID

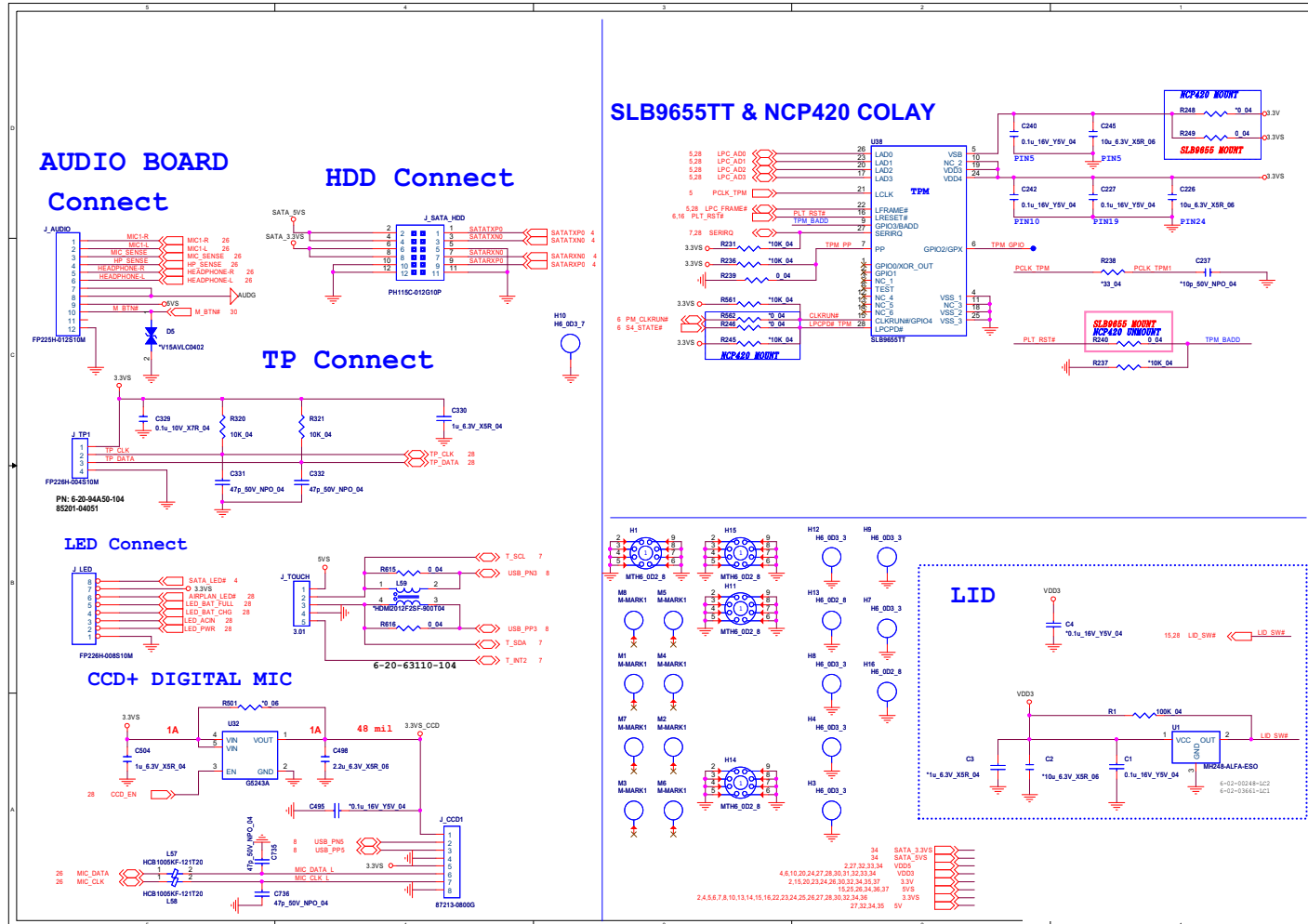

# KBC-ITE IT8587E

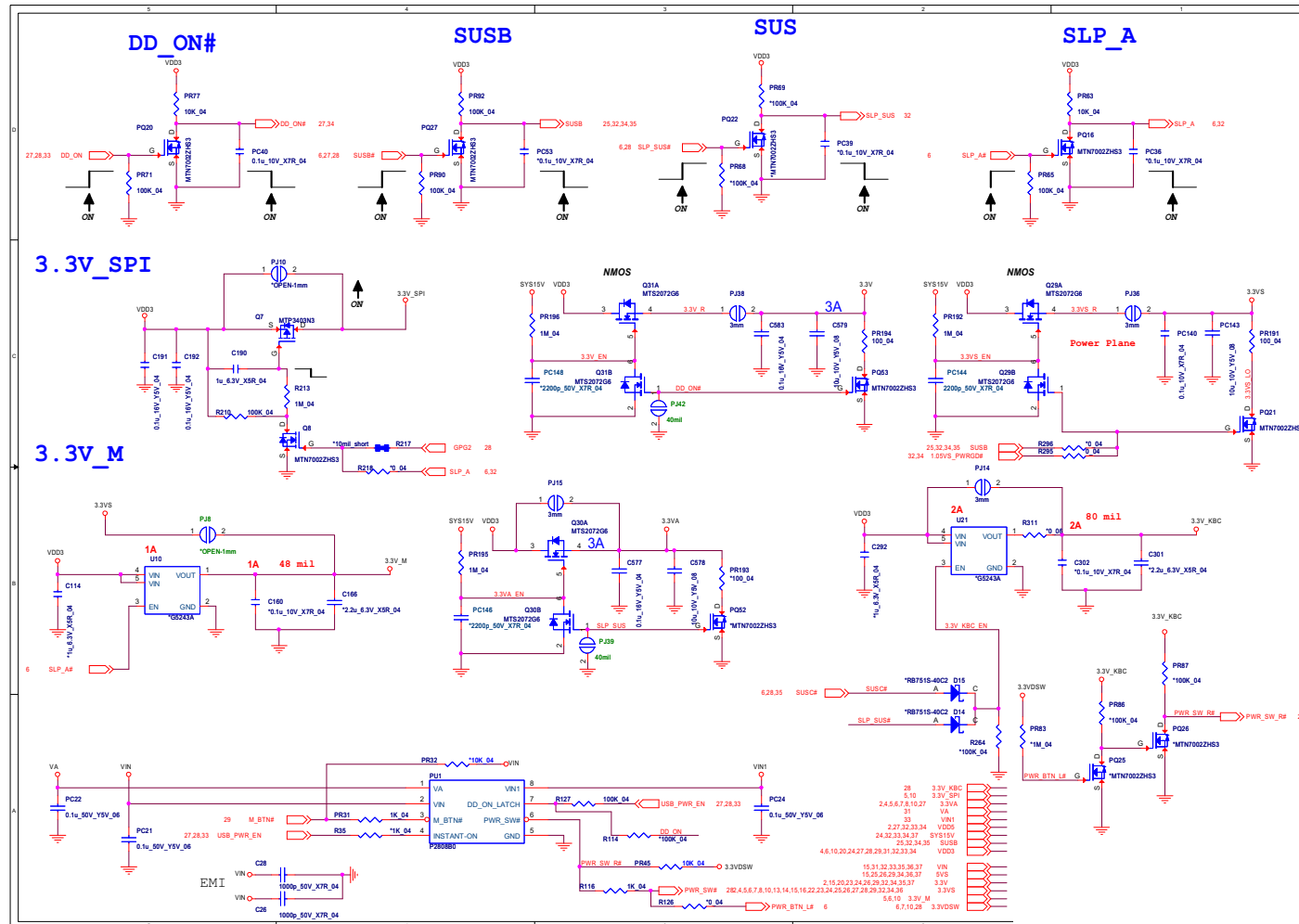

Sheet 30 of 42  
3.3V\_SPI, 3.3VS,  
3.3V\_M, 3.3V

B.Schematic Diagrams

# Charger, DC In

Sheet 31 of 42  
Charger, DC In

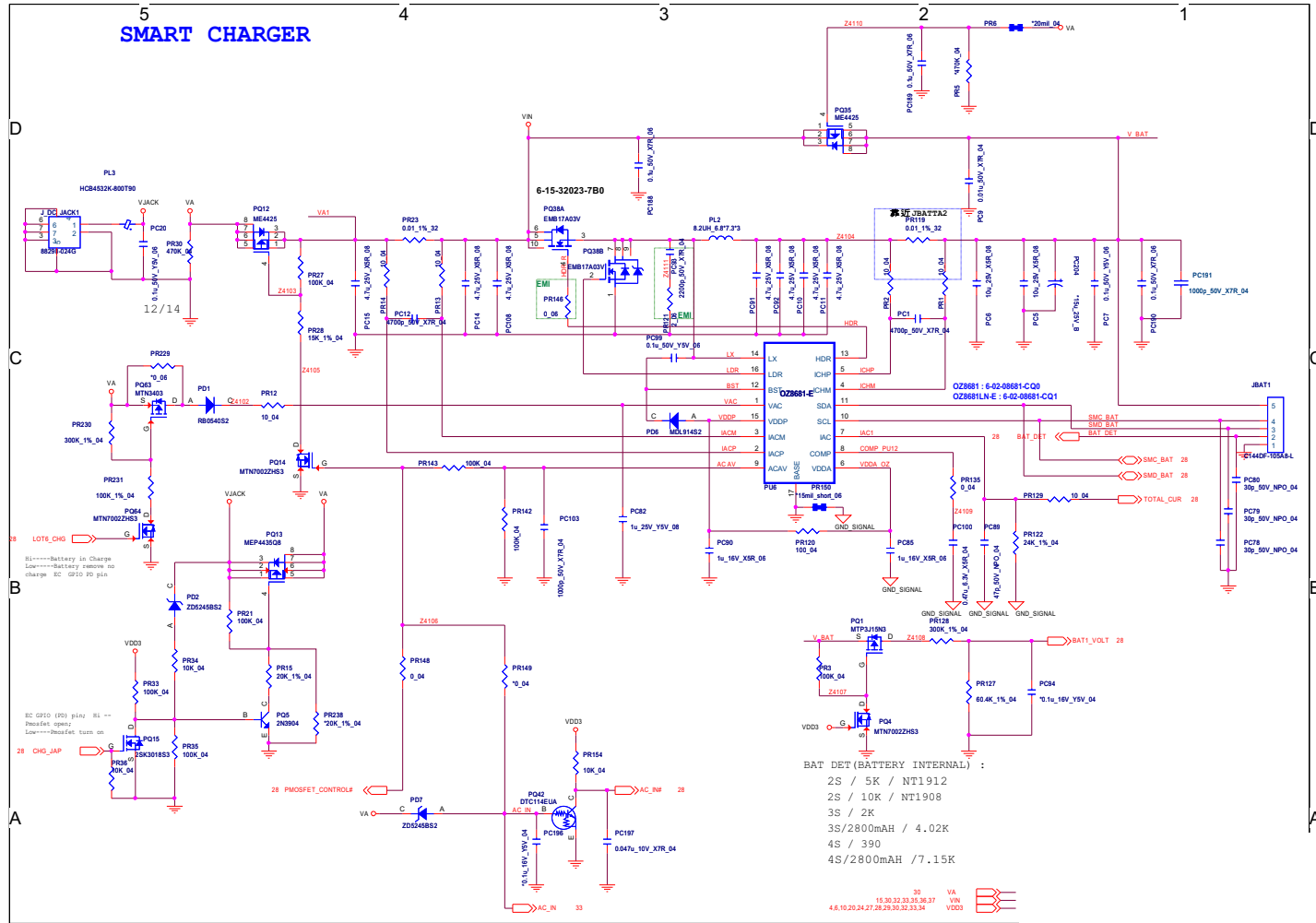

# 1.05V

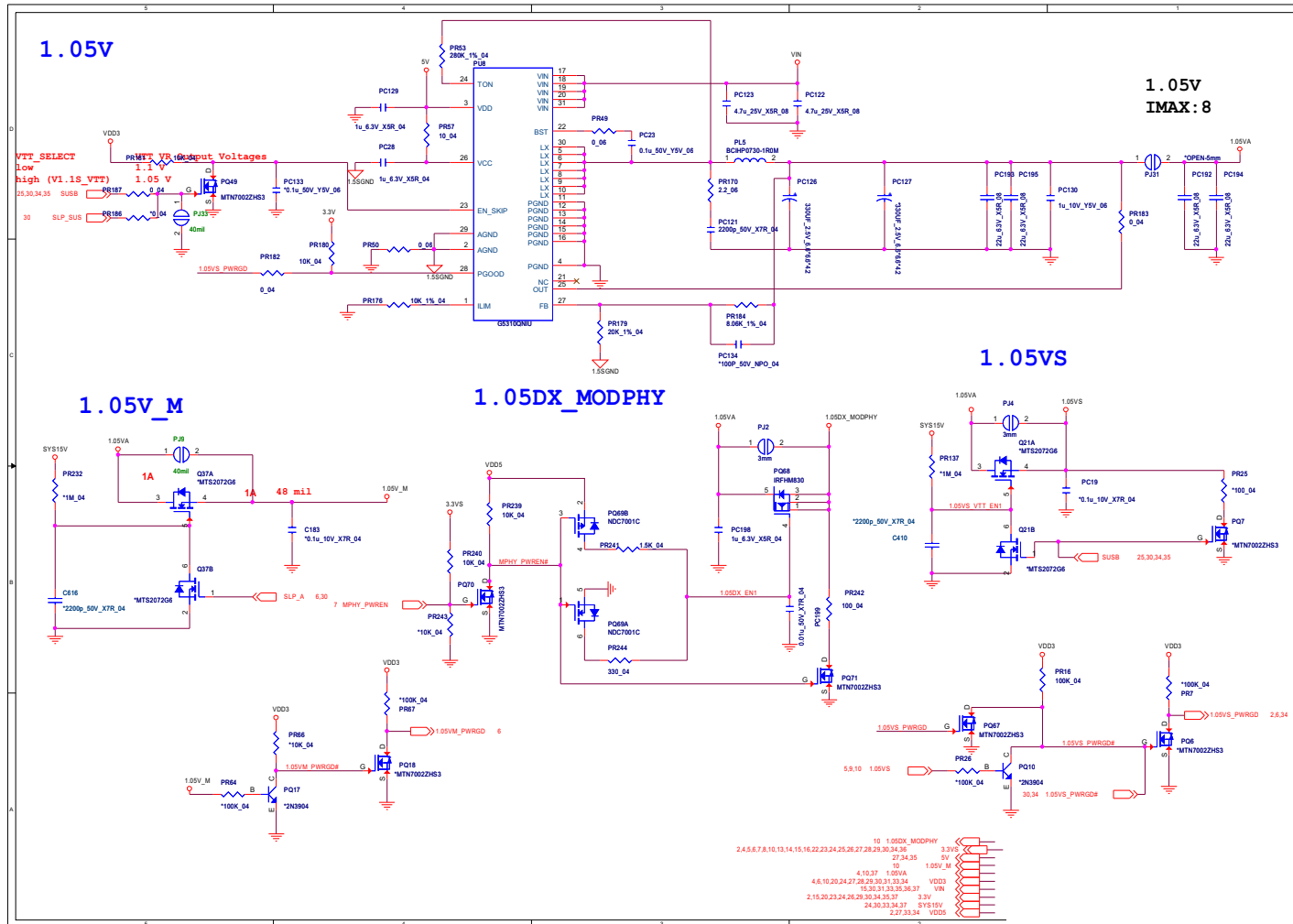

Sheet 32 of 42  
1.05V

B.Schematic Diagrams

# VDD3, VDD5

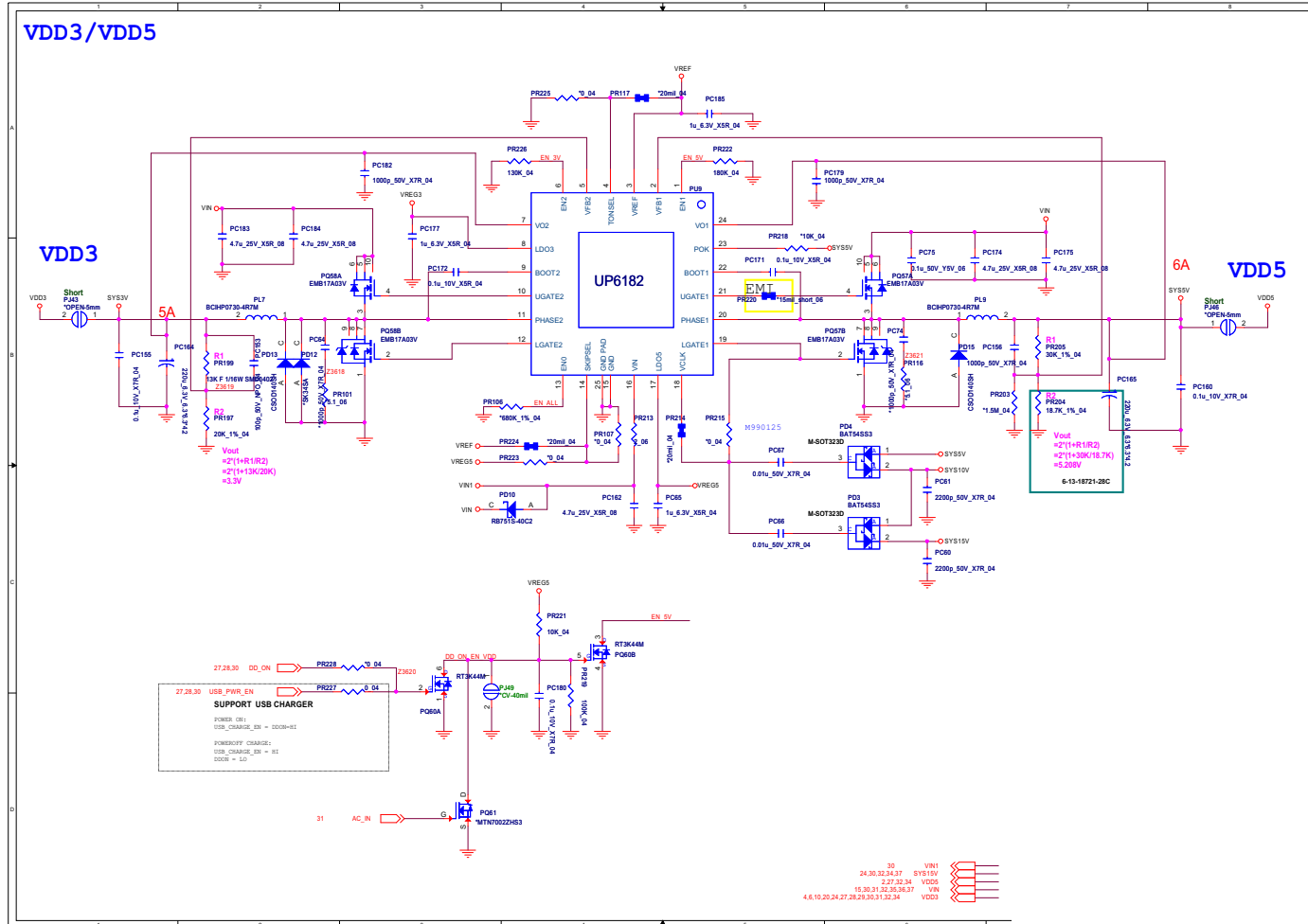

Sheet 33 of 42  
VDD3, VDD5

# 1.8VS, 1.5VS, 5V, 5VS, SATA\_5VS

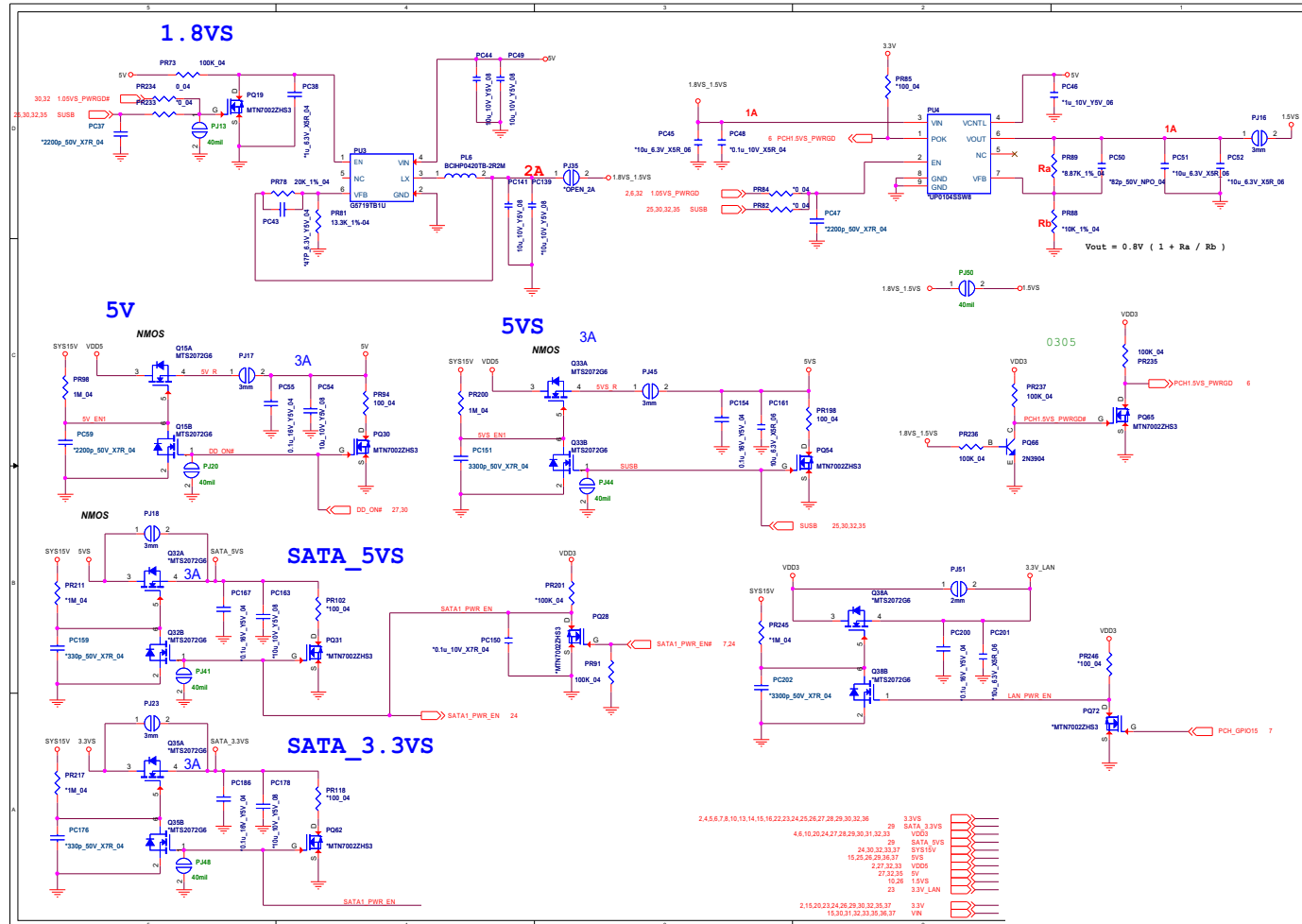

Sheet 34 of 42  
1.8VS, 1.5VS, 5V,  
5VS, SATA\_5VS

Schematic Diagrams

DDR 1.5V or 1.35V / 0.75VS PCH 1.5VS

B.Schematic Diagrams

Sheet 35 of 42  
DDR 1.5V or 1.35V /  
0.75VS PCH 1.5VS

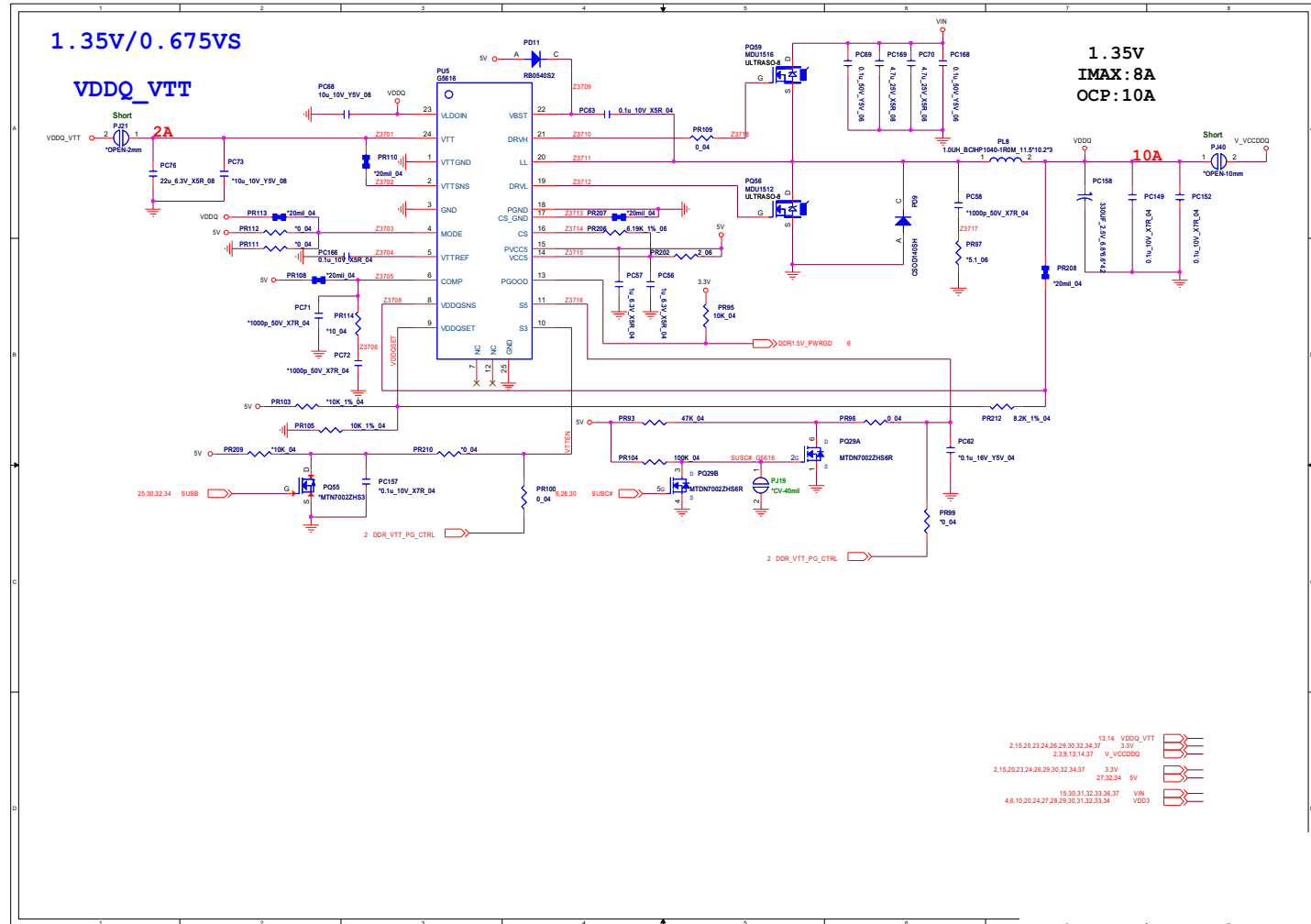



# VCORE

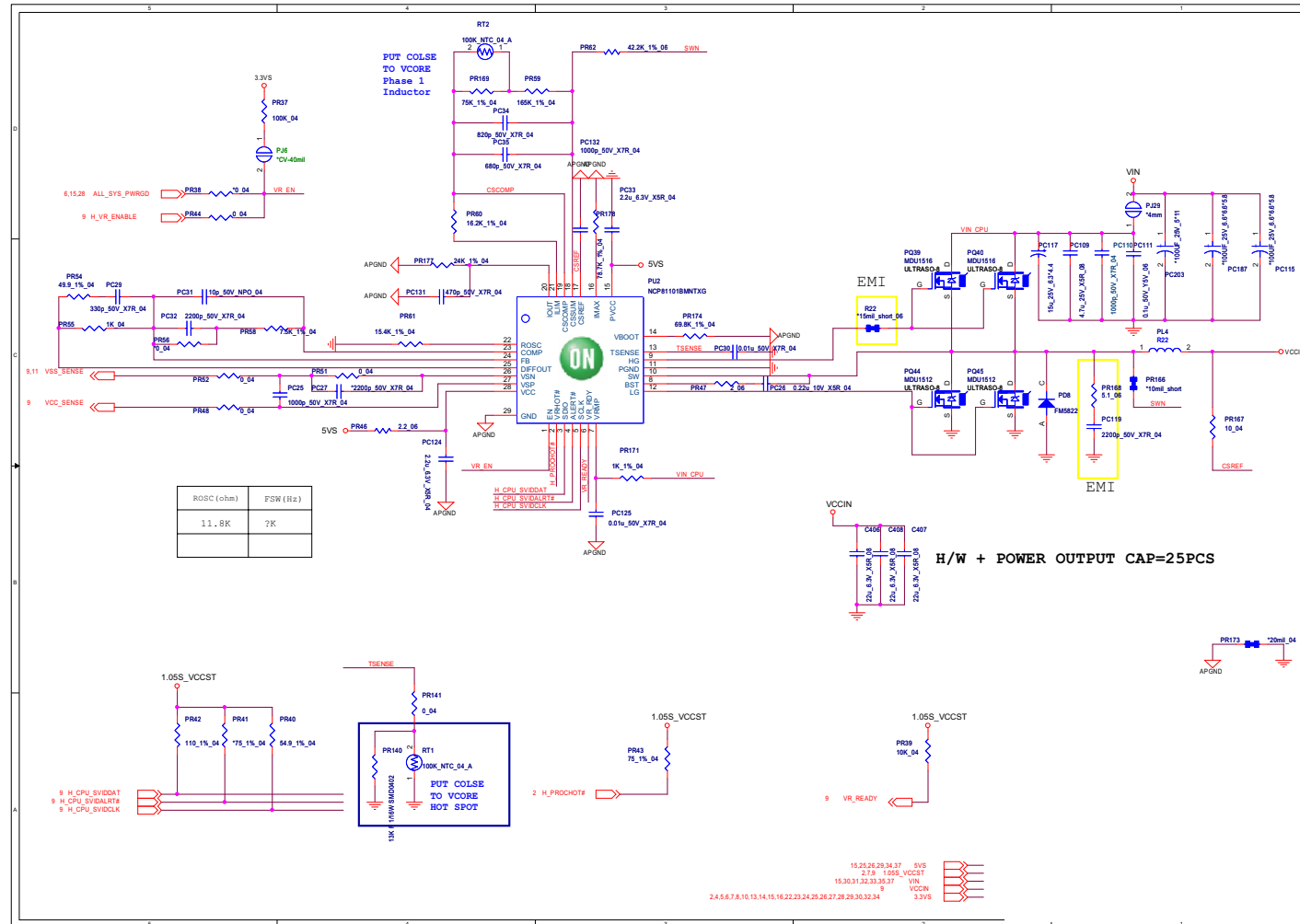

Sheet 36 of 42  
VCORE

# Schematic Diagrams

## N14P, NVVDD, PEX, FBVDDQ

B.Schematic Diagrams

Sheet 37 of 42  
N14P, NVVDD, PEX,  
FBVDDQ

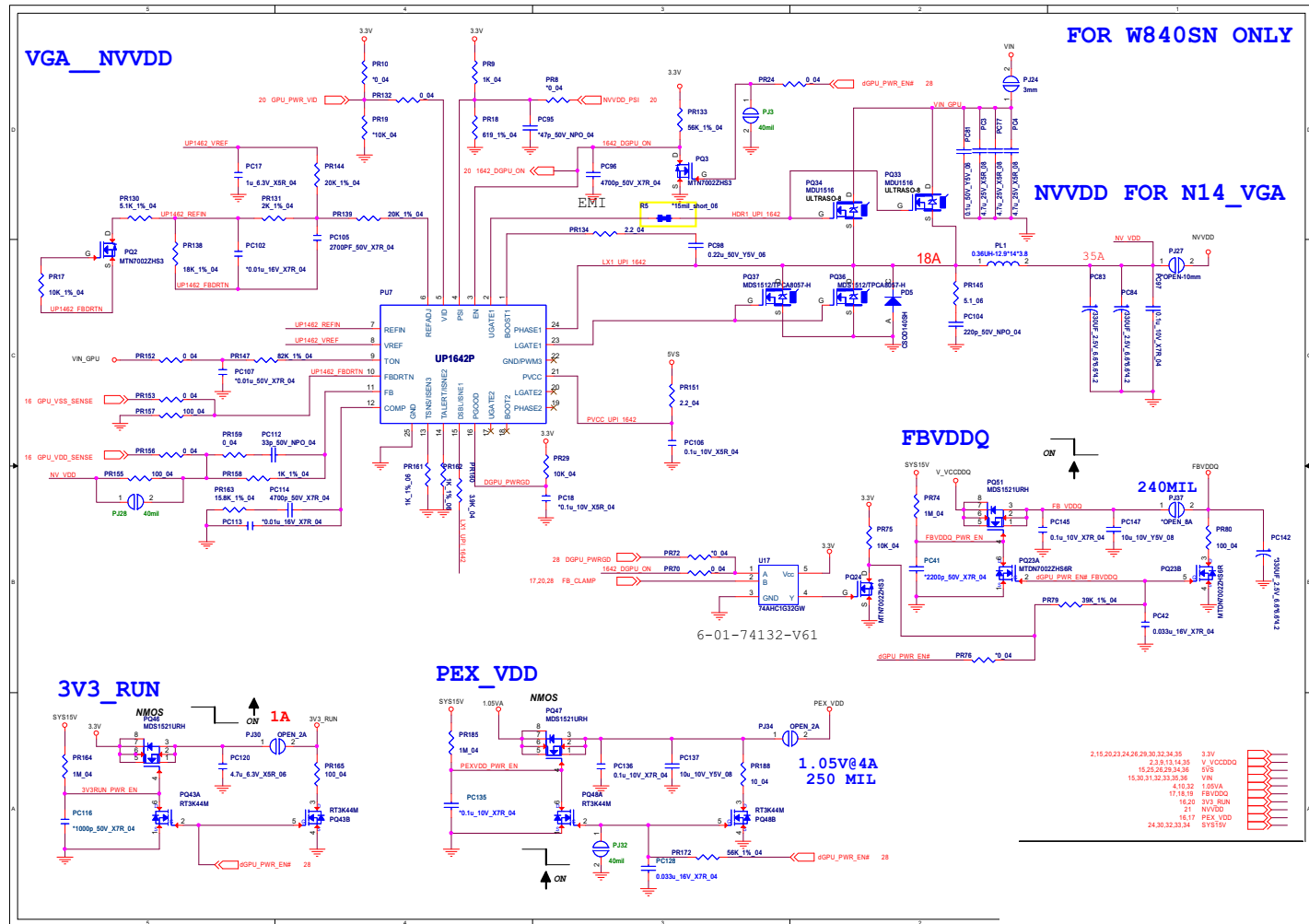

# Audio Board

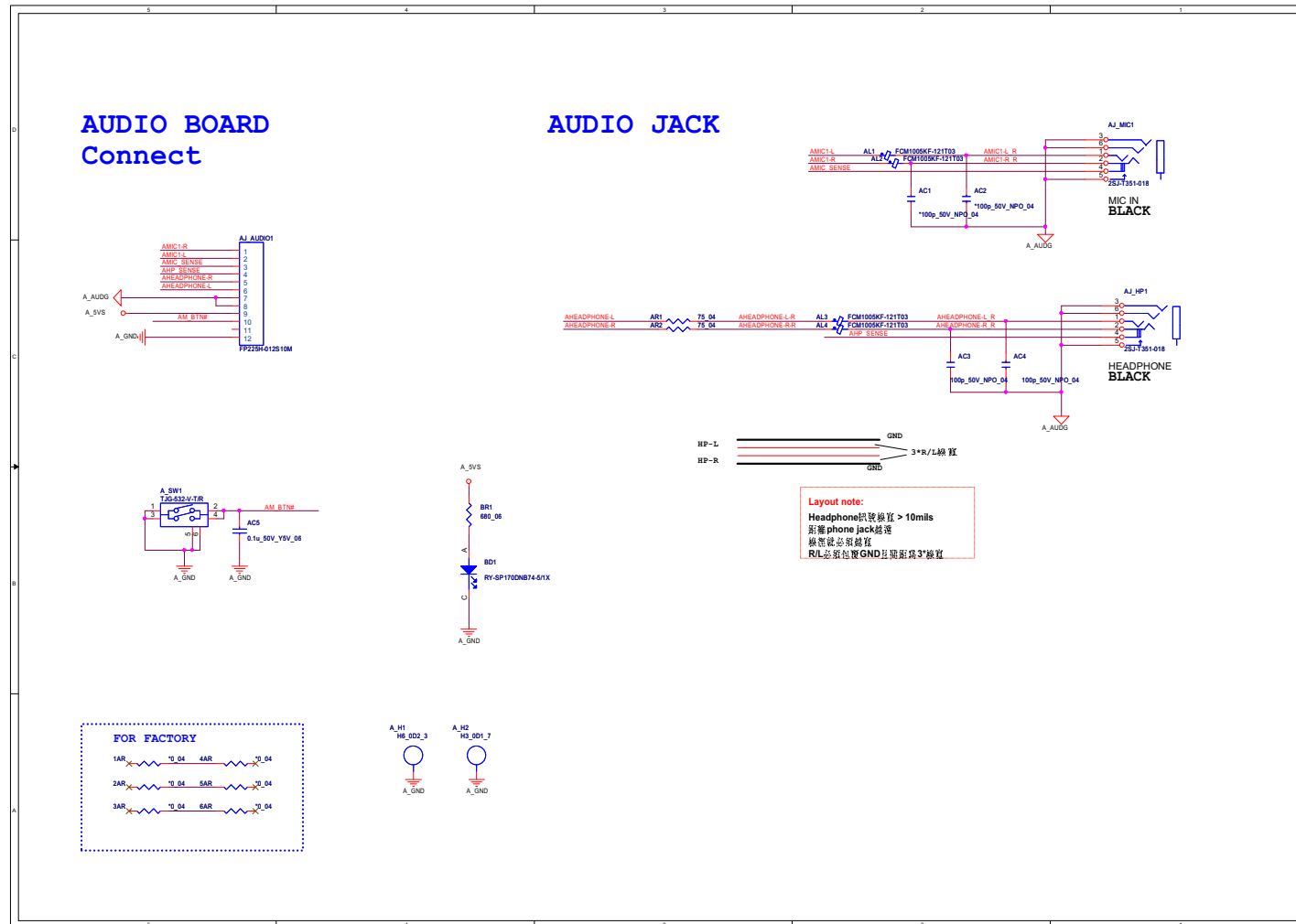

Sheet 38 of 42  
Audio Board

B.Schematic Diagrams

# HDD Board

Sheet 39 of 42  
HDD Board

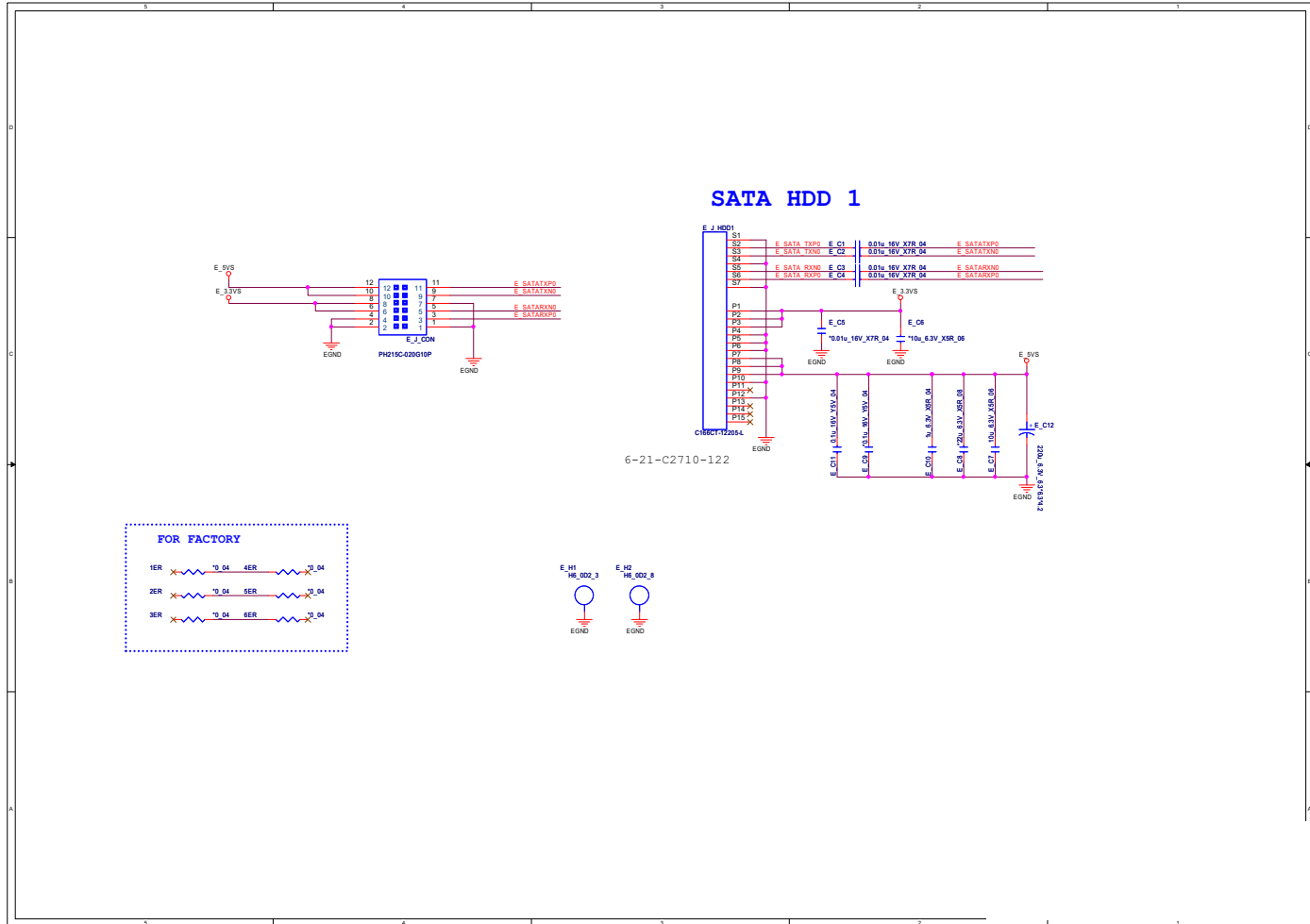

# Click Board

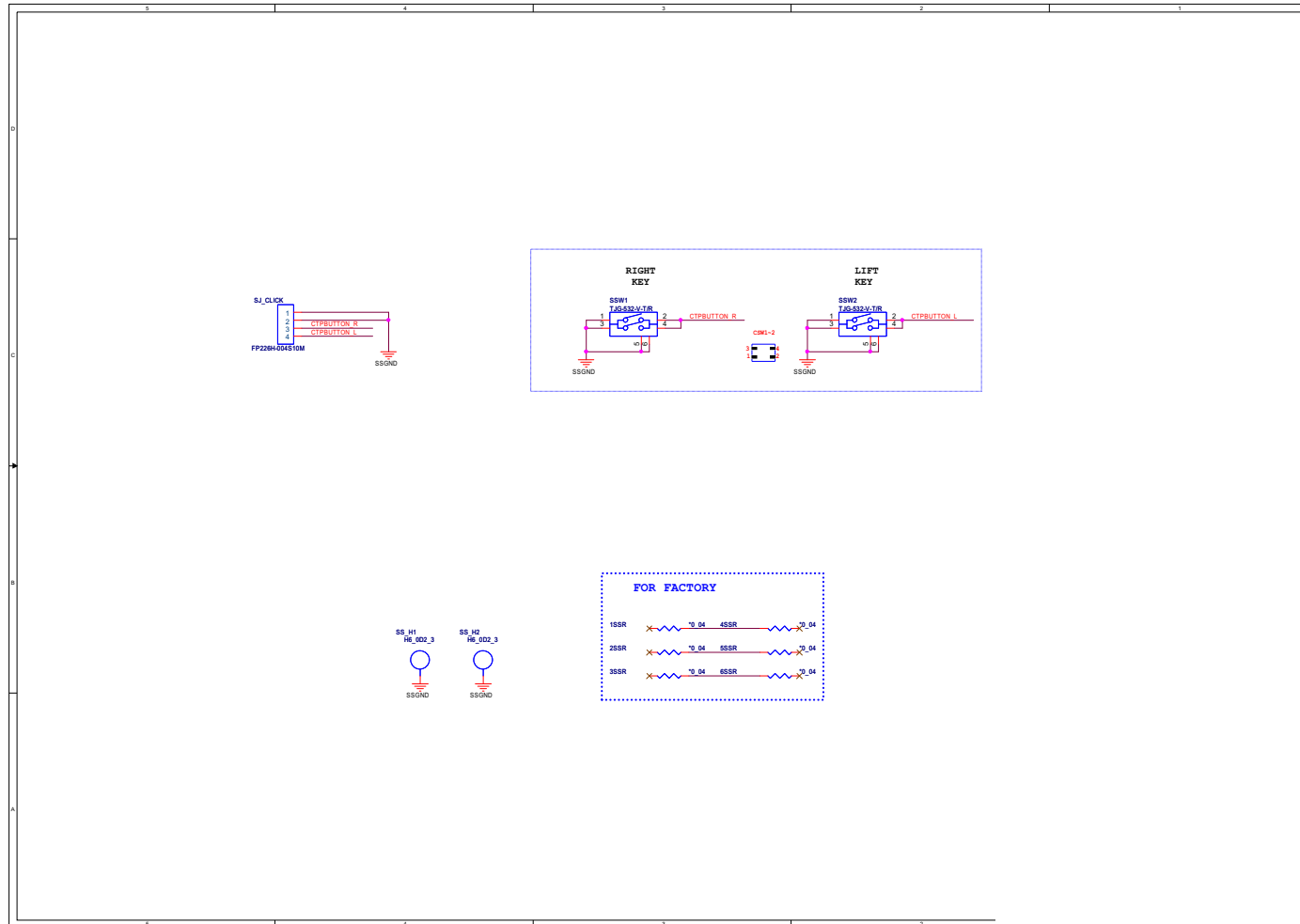

Sheet 40 of 42  
Click Board

# LED Board

Sheet 41 of 42  
LED Board

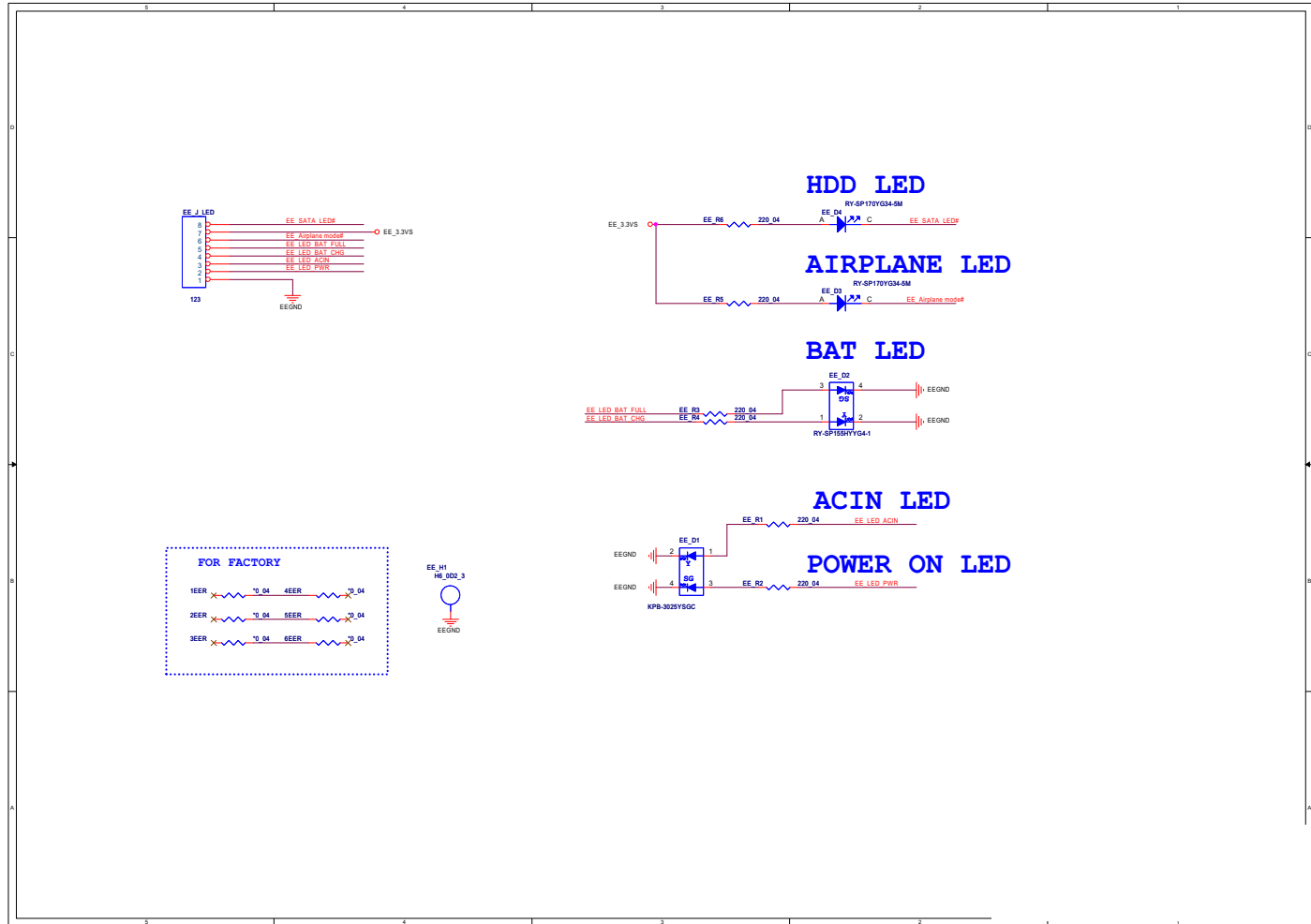

# Power Sequence

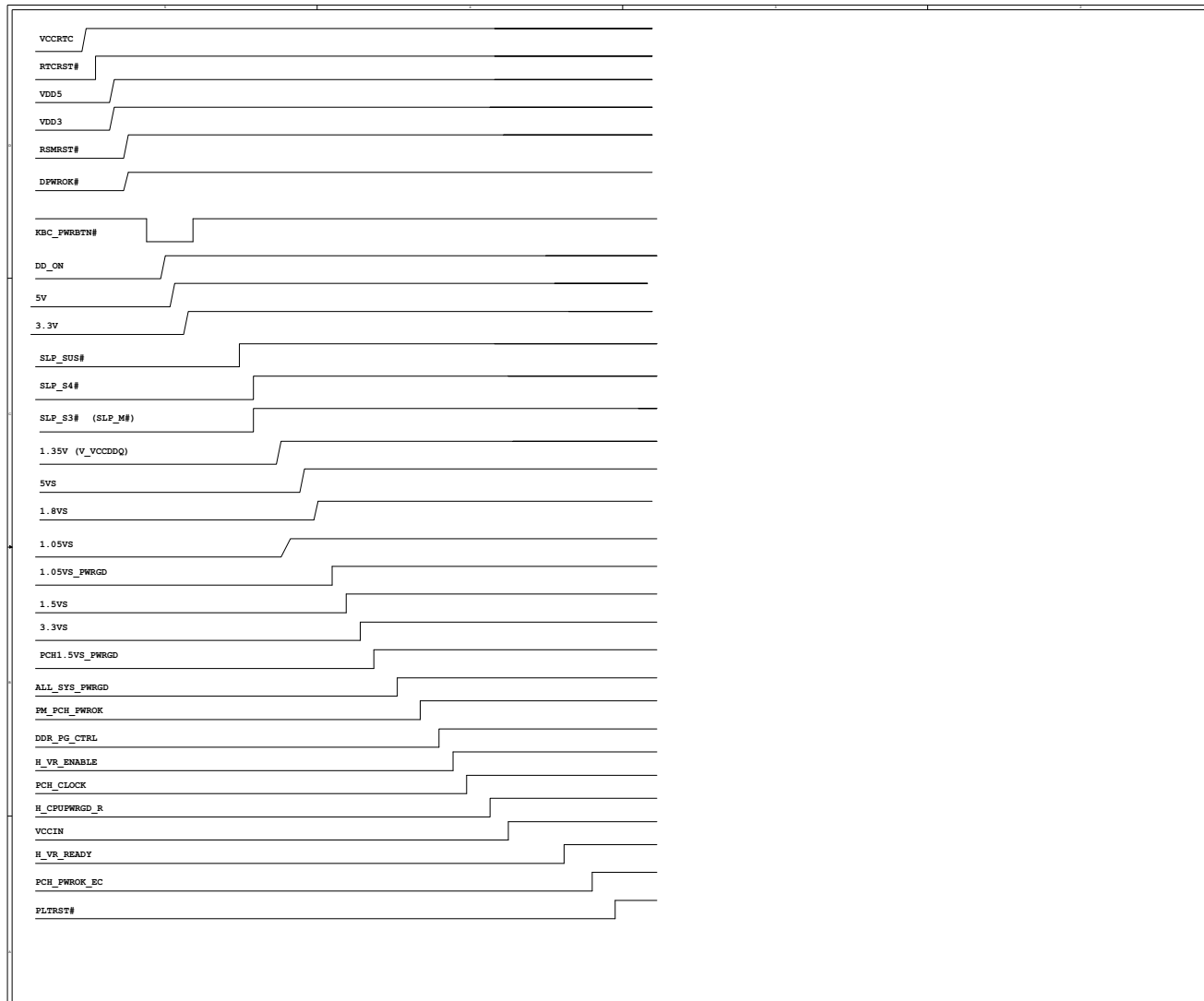

Sheet 42 of 42  
Power Sequence

**Schematic Diagrams**



# Appendix C: Updating the FLASH ROM BIOS

## To update the FLASH ROM BIOS, you must:

- Download the BIOS update from the web site.
- Unzip the files onto a bootable CD/DVD/USB Flash Drive.
- Reboot your computer from an external CD/DVD/USB Flash Drive.
- Use the flash tools to update the flash BIOS using the commands indicated below.
- Restart the computer booting from the HDD and press **F2** at startup enter the BIOS.
- Load setup defaults from the BIOS and save the default settings and exit the BIOS to restart the computer.
- After rebooting the computer you may restart the computer again and make any required changes to the default BIOS settings.

## Download the BIOS

1. Go to [www.clevo.com.tw](http://www.clevo.com.tw) and point to **E-Services** and click **E-Channel**.
2. Use your user ID and password to access the appropriate download area (BIOS), and download the latest BIOS files (the BIOS file will be contained in a batch file that may be run directly once unzipped) for your computer model (see sidebar for important information on BIOS versions).

## Unzip the downloaded files to a bootable CD/DVD/ or USB Flash drive

1. Insert a bootable CD/DVD/USB flash drive into the CD/DVD drive/USB port of the computer containing the downloaded files.
2. Use a tool such as Winzip or Winrar to unzip all the BIOS files and refresh tools to your bootable CD/DVD/USB flash drive (you may need to create a bootable CD/DVD with the files using a 3rd party software).

## Set the computer to boot from the external drive

1. With the bootable CD/DVD/USB flash drive containing the BIOS files in your CD/DVD drive/USB port, restart the computer and press **F2** (in most cases) to enter the BIOS.
2. Use the arrow keys to highlight the **Boot** menu.
3. Use the “+” and “-” keys to move boot devices up and down the priority order.
4. Make sure that the CD/DVD drive/USB flash drive is set first in the boot priority of the BIOS.
5. Press **F4** to save any changes you have made and exit the BIOS to restart the computer.



### BIOS Version

Make sure you download the latest correct version of the BIOS appropriate for the computer model you are working on.

You should only download BIOS versions that are **V1.01.XX or higher** as appropriate for your computer model.

Note that BIOS versions are not backward compatible and therefore you may not downgrade your BIOS to an older version after upgrading to a later version (e.g if you upgrade a BIOS to ver 1.01.05, you **MAY NOT** then go back and flash the BIOS to ver 1.01.04).

## BIOS Update

---

### Use the flash tools to update the BIOS

1. Make sure you are not loading any memory management programs such as HIMEM by holding the **F8** key as you see the message “**Starting MS-DOS**”. You will then be prompted to give “**Y**” or “**N**” responses to the programs being loaded by DOS. Choose “**N**” for any memory management programs.
2. You should now be at the DOS prompt e.g: DISK C:\> (C is the designated drive letter for the CD/DVD drive/USB flash drive).
3. **Type the following command** at the DOS prompt:

**C:\> Flash.bat**

4. The utility will then proceed to flash the BIOS.
5. You should then be prompted to press any key to restart the system or turn the power off, and then on again but make sure you remove the CD/DVD/USB flash drive from the CD/DVD drive/USB port before the computer restarts.

### Restart the computer (booting from the HDD)

1. With the CD/DVD/USB flash drive removed from the CD/DVD drive/USB port the computer should restart from the HDD.
2. Press **F2** as the computer restarts to enter the BIOS.
3. Use the arrow keys to highlight the **Exit** menu.
4. Select **Load Setup Defaults** (or press **F3**) and select “**Yes**” to confirm the selection.
5. Press **F4** to save any changes you have made and exit the BIOS to restart the computer.

### Your computer is now running normally with the updated BIOS

You may now enter the BIOS and make any changes you require to the default settings.